

AN ORDINANCE OF THE CITY COUNCIL OF THE CITY OF FRISCO, TEXAS, AMENDING FRISCO’S ZONING ORDINANCE, ORDINANCE NO. 11-04-09, AS AMENDED, SUBSECTION 4.04 (OFF-STREET PARKING AND LOADING REQUIREMENTS) OF SECTION 4 (SITE DEVELOPMENT REQUIREMENTS), BY ADDING SUBSECTION 4.04.12 (BICYCLE PARKING), AND SUBSECTION 7.01 (TERMS AND WORDS DEFINED) OF SECTION 7 (DEFINITIONS); ESTABLISHING REGULATIONS FOR BICYCLE PARKING; PROVIDING A PENALTY CLAUSE, SAVINGS/REPEALING CLAUSE, SEVERABILITY CLAUSE AND AN EFFECTIVE DATE; AND PROVIDING FOR THE PUBLICATION OF THE CAPTION HEREOF.

WHEREAS, the City Council of the City of Frisco, Texas (“City Council”) has investigated and determined that Subsection 4.04 (Off-Street Parking and Loading Requirements) of Section 4 (Site Development Requirements) and Subsection 7.01 (Terms and Words Defined) of Section 7 (Definitions) of the Zoning Ordinance, Ordinance No. 11-04-09, as amended (“Zoning Ordinance”), of the City of Frisco, Texas (“Frisco”) should be amended to establish regulations on bicycle parking by adding Subsection 4.04.12 (Bicycle Parking), as provided herein; and

WHEREAS, Frisco has complied with all legal notices and public hearings as required by law; and

WHEREAS, the City Council finds that it will be advantageous, beneficial and in the best interest of the citizens of Frisco to amend the Zoning Ordinance as set forth below.

NOW, THEREFORE, BE IT ORDAINED BY THE CITY COUNCIL OF THE CITY OF FRISCO, TEXAS:

SECTION 1: Findings Incorporated. The findings set forth above are incorporated into the body of this Ordinance as if fully set forth herein.

SECTION 2: Amendment to Subsection 4.04 (Off-Street Parking and Loading Requirements) of Section 4 (Site Development Requirements) of the Zoning Ordinance. Subsection 4.04 (Off-Street Parking and Loading Requirements) of Section 4 (Site Development Requirements) of the Zoning Ordinance is hereby amended to add Subsection 4.04.12 (Bicycle Parking) as follows:

“Subsection 4.04.12. Bicycle Parking

(A) Locations

- (1) Short-term bicycle parking must be located within 100 feet of the main public entrance of the building or facility.

- (2) Long-term bicycle parking must be located within 500 feet of the main public entrance of the building or facility.
- (3) Bicycle parking facilities shall not interfere with accessible paths of travel or accessible parking as required by the Americans with Disabilities Act, as amended.
- (4) When a rack is placed within a sidewalk or pedestrian right-of-way, a minimum of four (4) feet from the required rack dimension shall be provided for pedestrian clearance.
- (5) Bicycle racks shall be located in highly visible and well-lit areas to minimize theft and vandalism.
- (6) When automobile parking spaces are provided in a structured parking garage, all required long-term and short-term bicycle spaces shall be located inside the garage on the ground level. Alternative layout and design of racks to maximize space may be approved by the Director of Development Services.
- (7) Alternative Locations: In the event that compliance may not be feasible because of demonstrable hardship, the Director of Development Services may approve an alternative location.

(B) Layout and Design

- (1) Each bicycle rack shall be designed to accommodate two bicycle parking spaces (two bicycle spaces per rack) while using the allowed bike rack designs below:
 - a. Racks shall be designed to accommodate “U”-shaped locking devices and support the bicycle horizontally in two places.
 - b. The racks shall be constructed of durable materials to withstand permanent exposure to the elements, such as powder-coated metal or stainless steel.
 - c. Long-term bicycle parking shall feature a protective cover to shield bicycles from the elements and shall be clad in a similar architectural style and materials as the primary building or as approved by the Director of Development Services.
 - d. All bicycle parking spaces must be hard-surfaced or at minimum a compact gravel base.
 - e. All bicycle racks shall be securely anchored to the ground using a concrete footing and tamper-proof anchors.
 - f. Decorative bicycle racks that enhance the sense of place and contribute to the character of the development are encouraged but are subject to approval by the Director of Development Services.

Fig. 1: Examples of Typical Bicycle Parking Designs Allowed and Not Allowed:

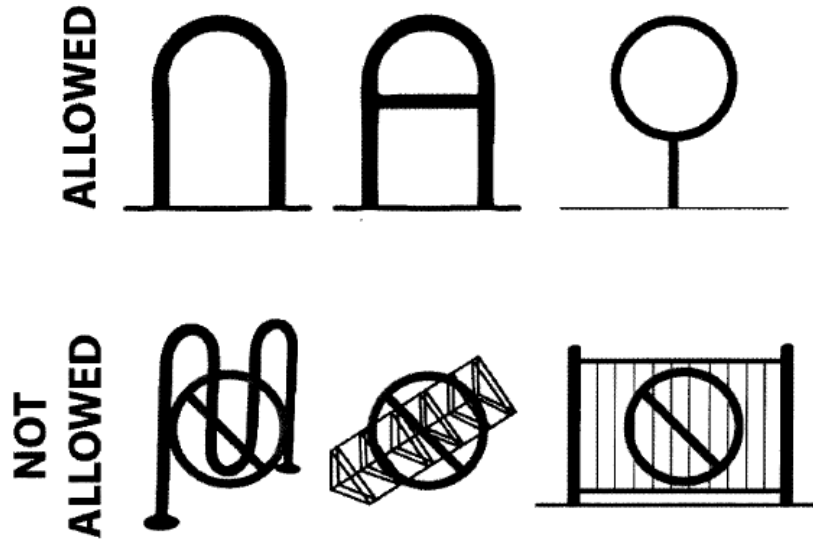

- (2) Bicycle Parking Space Size, Access Aisles and Vertical Clearance
- a. Bicycle racks shall provide clearance from other objects by using a standard footprint that is at least four (4) feet wide by six (6) feet long, as depicted below, and shall hold at least two bicycles.

Fig. 2: Examples of Bicycle Parking Footprint and Dimensions

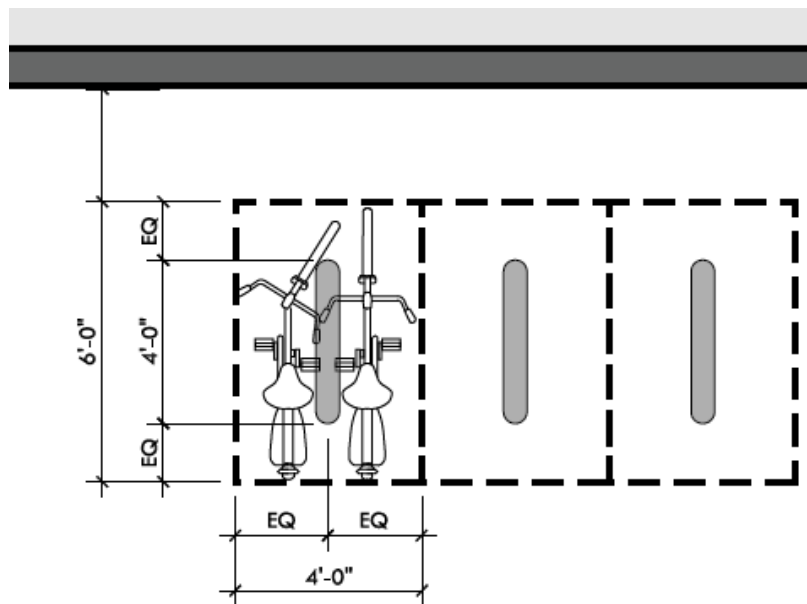

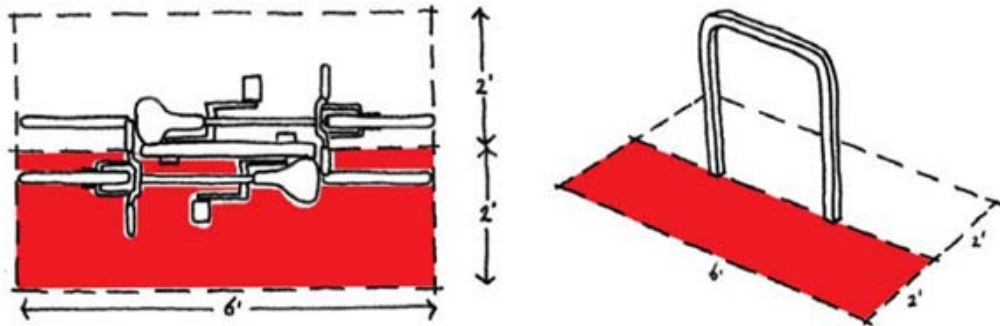

- (3) In cases where bicycle parking spaces are not visible from the primary drive aisle approaching the building, signage shall be used to direct cyclists safely to bicycle parking areas (Manual for Uniform Traffic Devices sign D4-3). These signs shall not be placed in the public right-of-way.

Fig. 3: Manual for Uniform Traffic Devices Sign D4-3



D4-3

(C) Bicycle Corrals

In areas with limited sidewalk space and frequent bicycle activity, bicycle parking shall be provided in “bike corrals” located in the vehicular parking area adjacent to a curb. Bike corrals make use of parking lot areas that are unsuitable for automobile parking. When replacing a single automobile parking space, a corral can generally fit eight to twelve bicycles. Design will be considered as context dictates as approved by the Director of Development Services.

Bicycle corrals shall be designed to distinguish and define the parking stall they inhabit for visibility and safety purposes. The corral is generally surrounded by a

0 painted white box on the pavement with flexible vertical delineators and a wheel stop where vehicles in adjacent parking spots might back into the corral. No vertical element of the structure may be taller than four feet tall, unless approved by the Director of Development Services.

(D) Bicycle Parking Requirement

The number of bicycle parking racks shall be based on the required automobile parking spaces and shall be provided in accordance with the following. Where fractional bicycle parking spaces result, the spaces required shall be rounded up to the nearest whole number.

Fig. 4: Bicycle Parking Standard Chart

<p>Non-Residential</p>	<p>0-40 required auto spaces = 2 short-term bicycle parking spaces minimum 41-60 required auto spaces = 4 short-term bicycle parking spaces minimum 61-80 required auto spaces = 6 short-term bicycle parking spaces minimum 81-100 required auto spaces = 8 short-term bicycle parking spaces minimum 101+ required auto spaces = minimum 10 short-term bicycle parking spaces or 2.5% of required automobile spaces, whichever is greater, will be provided as short-term bicycle parking spaces</p>
<p>Multifamily Residential (MF-15 & MF-19)</p>	<p>The minimum number of long-term bicycle parking spaces shall be equal to 10% of the required auto spaces.</p>

- (1) Bicycle parking is required for all commercial uses except: Accessory Structure, Antenna and/or Antenna Support Structure (Commercial), Antenna and/or Antenna Support Structure (Non-Commercial), Places of Worship, Hotel, Mini-Warehouse/Self-Storage, Mobile Food Vendor, Private Utility, Oil Well/Gas Well and Mineral Extraction, Recycling Collection Point, Sewage Treatment Plant/Pumping Station, Telephone Exchange, Temporary Building, Utility Distribution/Transmission Line, Water Treatment Plant.
- (2) Bicycle parking for residential uses is only required in Multifamily-15 and Multifamily-19 uses.
- (3) Bicycle parking for Licensed Child-Care Facility and Hospital uses

- shall be calculated using required employee automobile parking.
- (4) The number of required and provided automobile parking spaces and bicycle parking spaces shall be shown in a chart format on the site plan. The location and footprints of bicycle racks corrals shall be shown on the site, as well as the location of any bicycle parking signage.
 - (5) The number of required automobile parking spaces for a site plan may be reduced by the number of bicycle parking spaces provided on that site plan, subject to a maximum reduction of five percent (5%).
 - (6) In all cases where bicycle parking is required, no fewer than two (2) spaces (one rack) shall be required.
 - (7) Up to half of the required short-term bicycle parking spaces may be substituted with long-term bicycle parking spaces.
 - (8) When the intensity of use of any building, structure or premises shall be increased through addition of dwelling units, gross floor area, seating capacity or other units of measurement specified herein that requires additional automobile parking spaces, additional bicycle parking as required herein shall be provided for such increase in intensity of use.”

SECTION 4: Amendment to Subsection 7.01 (Terms and Words Defined) of Section 7 (Definitions) of the Zoning Ordinance. Subsection 7.01 (Terms and Words Defined) of Section 7 (Definitions) of the Zoning Ordinance is hereby amended to add the terms “Short-Term Bicycle Rack,” “Long-Term Bicycle Rack” and “Bicycle Corral” as follows:

“Subsection 7.01. Terms and Words Defined

...

Bicycle Corral

A group of either short-term or long-term bicycle parking spaces that are located in the vehicular parking area adjacent to the curb. The corral is generally surrounded by a painted white box on the street with flexible vertical delineators and a wheel stop where vehicles are likely to back into the adjacent parking spot.

...

Bicycle Rack, Long-Term

A bicycle parking fixture that provides at least two bicycle spaces and includes at least a four-foot-wide by six-foot-long dimension, intended for parking more than three hours, and is fully protected from the elements.

...

Bicycle Rack, Short-Term

A bicycle parking fixture that provides at least two bicycle spaces and includes at least a four-foot-wide by six-foot-long dimension, intended for parking less than three hours.

...”

SECTION 5: Savings/Repealing. The Zoning Ordinance shall remain in full force and effect, save and except as amended by this or any other Ordinance. All provisions of any ordinance in conflict with this Ordinance are hereby repealed to the extent they are in conflict, but such repeal shall not abate any pending prosecution for violation of the repealed ordinance, nor shall the repeal prevent a prosecution from being commenced for any violation if occurring prior to the repeal of the ordinance. Any remaining portions of said ordinances shall remain in full force and effect.

SECTION 6: Severability. Should any section, subsection, sentence, clause or phrase of this Ordinance be declared unconstitutional and/or invalid by a court of competent jurisdiction, it is expressly provided that any and all remaining portions of this Ordinance shall remain in full force and effect. The City Council hereby declares that it would have passed this Ordinance, and each section, subsection, clause or phrase thereof, regardless of whether any one or more sections, subsections, sentences, clauses or phrases is declared unconstitutional and/or invalid.

SECTION 7: Penalty. Any person, firm, corporation or entity violating any provision of this Ordinance or the Zoning Ordinance, as they exist or may be amended, shall be deemed guilty of a misdemeanor, and upon conviction therefore, shall be fined in a sum not exceeding TWO THOUSAND AND NO/100 DOLLARS (\$2,000.00). Each continuing day’s violation shall constitute a separate offense. The penal provisions imposed under this Ordinance shall not preclude Frisco from filing suit to enjoin the violation. Frisco retains all legal rights and remedies available to it pursuant to local, state and federal law.

SECTION 8: Effective Date. This Ordinance shall become effective from and after its adoption and publication as required by law and the City Charter.

[The remainder of this page intentionally left blank.]

DULY PASSED AND APPROVED BY THE CITY COUNCIL OF THE CITY OF FRISCO, TEXAS on this 17th day of May, 2016.

Maher Maso

Maher Maso, Mayor

**ATTESTED TO AND
CORRECTLY RECORDED BY**

Jenny Page

Jenny Page, City Secretary



APPROVED AS TO FORM:

Ryan D. Pittman

Abernathy Roeder Boyd & Hullett, P.C.
Ryan D. Pittman, City Attorneys

Dates of Publication: May 20 & 27, 2016, *Frisco Enterprise*