

Southern Dallas County Regional Veloweb Alignment Study Summary Report

May 2021



North Central Texas
Council of Governments



Duncanville
City of Champions



City of Dallas



CEDAR HILL
WHERE OPPORTUNITIES GROW NATURALLY



Texas
Department
of Transportation



DESOTO
TEXAS



HALFF

TABLE OF CONTENTS

Project Study Description1

Overall Study Area Map.....2

Overall Cost Estimate Summary.....3

Summary of Findings5

Dallas Trail A.....5

Cedar Hill Trail A8

Cedar Hill Trail B11

Cedar Hill Trail C13

Duncanville Trail A17

Duncanville Trail B21

Duncanville Trail C23

DeSoto Trail A.....26

DeSoto Trail B.....29

DeSoto Trail C.....31

DeSoto Trail C (ALT)34

DeSoto Trail D.....37

DeSoto Trail E.....40

Lancaster Trail A44

Lancaster Trail A (ALT)48

Lancaster Trail B51

Lancaster Trail C54

Appendix

Agency Contacts – Appendix A.....58

TxDOT Meeting Minutes – Appendix B60

Lancaster Town Square Concepts – Appendix C.....67

PROJECT STUDY DESCRIPTION

The North Central Texas Council of Governments (NCTCOG) partnered with Dallas County and five local governments including the City of Cedar Hill, City of Duncanville, City of DeSoto, City of Lancaster, and the City of Dallas, and the Texas Department of Transportation (TxDOT) to conduct an alignment study for a Regional Veloweb corridor across southern Dallas County. The project study area (refer to Overall Study Area Map) was bounded on the west in the City of Cedar Hill by the existing sidepath along FM 1382 near the intersection of W. Pleasant Run Road, and to the east in the City of Lancaster, with the existing sidepath along E. Pleasant Run Road, near the intersection of N. Lancaster-Hutchins Road. The alignment study focused on the gaps between various existing or planned shared use paths and bikeways in each of the cities.

The alignment study, completed in April 2021, focused on 15 sidepath segments with two alternative alignments for a total of 14.13 miles which connect existing, funded, and planned sidepath and on-street bikeway segments that will complete a continuous east-west connection through southern Dallas County. The various segments once constructed will result in a continuous sidepath alignment that connects multiple existing and proposed sidepaths through Cedar Hill, Duncanville, DeSoto, and Lancaster with existing and funded paths in Dallas and Grand Prairie. The western portion of the study area also connects with existing and funded sidepaths in Dallas along Mountain Creek Parkway and FM 1382, and W. Camp Wisdom Road extending westward into Grand Prairie. The eastern portion connects with an existing sidepath along Pleasant Run Road at Lancaster Hutchins Road extending east to Miller Ferry Road in the City of Wilmer.

The preliminary design completed with the Study consists of a minimum 12-ft. wide, hard surface, accessible shared use path (sidepath), shared use sidepath bridges, boardwalks, at-grade railroad crossings, and crossings of major highways (US 67 and Interstate Highway (IH) 35E). The various sections of the sidepath alignment are anticipated to be implemented in phases by each of the local communities.

NCTCOG procured professional services from Halff Associates, Inc. to evaluate alignment options, recommend a preferred route, and conduct five percent preliminary engineering for a Regional Veloweb shared-use path consistent with *The Guide for the Development of Bicycle Facilities* by the American Association of State Highway and Transportation Officials. A design development schematic, environmental summary, right-of-way and/or easement requirements, and opinions of probable costs by jurisdiction are provided and serve as an accessory to this report.

OVERALL STUDY AREA MAP

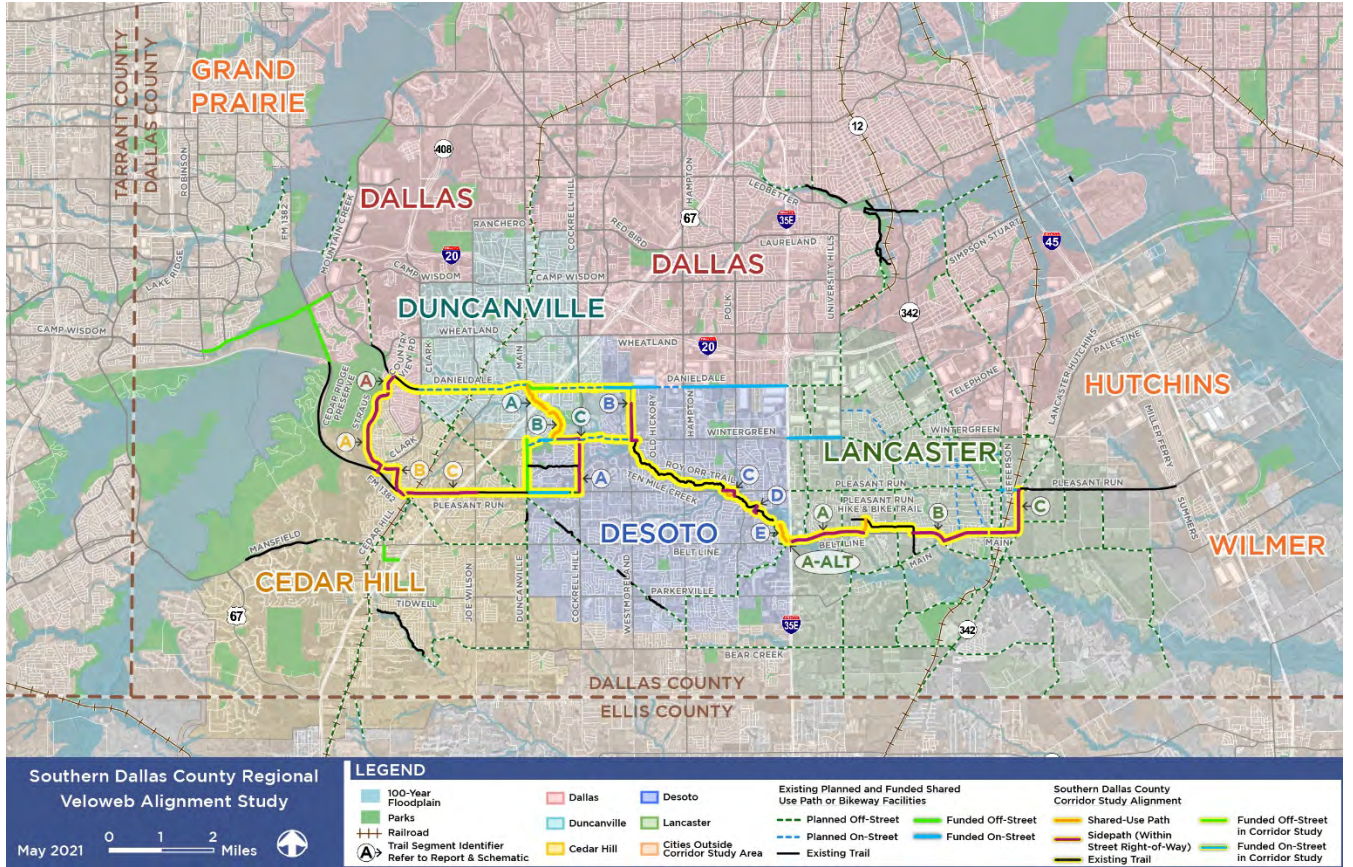

OVERALL COST ESTIMATE SUMMARY (2021)

JURISDICTION	TRAIL SEGMENT	TRAIL SEGMENT LIMITS	TRAIL LENGTH (Feet)	TRAIL LENGTH (Miles)	TOTAL ESTIMATED COST
					12' Wide Shared Use Path (Trail)
Dallas	Dallas-A (Country View Rd.)	Country View Rd. - City Limit (Sorcery Rd.)	1,506	0.29	\$ 630,000
TOTAL DALLAS			1,506	0.29	\$ 630,000
Cedar Hill	CH-A (Straus Rd.)	City Limit (Sorcery Rd.) - New Clark Rd. / FM 1382	9,933	1.88	\$ 3,446,000
Cedar Hill	CH-B (Straus Rd.)	Old Straus Rd. - Pleasant Run Rd.	4,790	0.91	\$ 1,753,000
Cedar Hill	CH-C (Pleasant Run Rd.)	FM 1382 - Joe Wilson Rd.	7,388	1.40	\$ 4,257,000
TOTAL CEDAR HILL			22,111	4.19	\$ 9,456,000
Duncanville	D-A (Road Along Ten Mile Creek)	Main St. - Waterview Park	3,413	0.65	\$ 2,633,000
Duncanville	D-B (Off-Road Along Ten Mile Creek)	Waterview Park - Wintergreen Rd.	3,761	0.71	\$ 1,640,000
Duncanville	D-C (Wintergreen Rd.)	Ten Mile Creek to Cockrell Hill Rd.	2,631	0.50	\$ 702,000
TOTAL DUNCANVILLE			9,805	1.86	\$ 4,975,000
DeSoto	DS-A (Cockrell Hill Rd.)	Wintergreen Rd. - Pleasant Run Rd.	5,370	1.02	\$ 1,981,000
DeSoto	DS-B (Westmoreland Rd.)	Daniel Farms - Roy Orr Trail	4,277	0.81	\$ 1,207,000
DeSoto	DS-C (Pleasant Run Rd.)	Roy Orr Trail to Polk St.	1,485	0.28	\$ 661,000
DeSoto	DS-C-ALT (Pleasant Run Rd. Undercrossing)	Ten Mile Creek to Roy Orr Trail	1,375	0.26	\$ 2,132,000
DeSoto	DS-D (Meadows Pkwy. & Plantation Dr.)	Roy Orr Trail / Meadows Pkwy. - Roy Orr Trail / Plantation Dr.	996	0.19	\$ 67,000
DeSoto	DS-E (Along Ten Mile Creek)	Murphy Hills Park – IH 35E / City Limit	2,457	0.47	\$ 2,372,000
TOTAL DESOTO			15,960	3.03	\$ 8,420,000
Lancaster	L-A (Belt Line Rd.)	IH 35E / City Limit - Pleasant Run Hike & Bike Trail / R.P. Millbrook Elementary School	8,902	1.69	\$ 2,976,000
Lancaster	L-A-ALT (IH 35E Undercrossing)	IH 35E / City Limit - Belt Line Rd.	997	0.19	\$ 1,939,000
Lancaster	L-B (W. Belt Line Rd. & Main St.)	Pleasant Run Hike & Bike Trail - Dallas Avenue (SH 342)	8,461	1.60	\$ 2,589,000
Lancaster	L-C (Main St. & Lancaster Hutchins Rd.)	Dallas Ave. (SH 342) - Pleasant Run Rd.	6,845	1.30	\$ 2,268,000
TOTAL LANCASTER			25,205	4.78	\$ 9,772,000
GRAND TOTAL			74,587	14.13	\$33,253,000

SOUTHERN DALLAS COUNTY REGIONAL VELOWEB ALIGNMENT STUDY

OPINION OF PROBABLE CONSTRUCTION COST (5% SCHEMATIC SET) - MAY 2021 (2021 BASE BID TOTALS INCLUDE A 20% CONTINGENCY)				CITY TOTAL PROJECTED ESTIMATE WITH INFLATION				
JURISDICTION	TRAIL SEGMENT TOTAL PER CITY (Feet)	TRAIL SEGMENT TOTAL PER CITY (Miles)	2021 TOTAL ESTIMATED COST	2022*	2023*	2024*	2025*	2026*
Dallas	1,506	0.29 Miles	\$ 630,000	\$ 648,900	\$ 668,367	\$ 688,418	\$ 709,071	\$ 730,343
Cedar Hill	22,111	4.19 Miles	\$ 9,456,000	\$ 9,739,680	\$ 10,031,870	\$ 10,332,827	\$ 10,642,811	\$ 10,962,096
Duncanville	9,805	1.86 Miles	\$ 4,975,000	\$ 5,124,250	\$ 5,277,978	\$ 5,436,317	\$ 5,599,406	\$ 5,767,389
DeSoto	15,960	3.03 Miles	\$ 8,420,000	\$ 8,672,600	\$ 8,932,778	\$ 9,200,761	\$ 9,476,784	\$ 9,761,088
Lancaster	25,205	4.78 Miles	\$ 9,772,000	\$ 10,065,160	\$ 10,367,115	\$ 10,678,128	\$ 10,998,472	\$ 11,328,426
GRAND TOTAL	74,587 Feet	14.13 Miles	\$ 33,253,000	\$ 34,250,590	\$ 35,278,108	\$ 36,336,451	\$ 37,426,544	\$ 38,549,341

*Projected inflation costs are approximated at 3% per year

SUMMARY OF FINDINGS

Dallas Trail A: Country View Road (Mountain Creek Parkway to Cedar Hill/Dallas City limits near Sorcey Rd.)

Trail Alignment

Trail Segment A in Dallas will serve as a sidepath connection from the existing sidepath along Mountain Creek Parkway to Cedar Ridge Preserve, traveling along the west side of Country View Rd. Between Mountain Creek Pkwy and Long Canyon Trail, the sidepath will replace an existing sidewalk and will follow along the front yards of residential property owners, requiring some mailboxes and utilities to be adjusted or moved. The mailbox adjustment will require coordination with US Postal Service since the relocated mailboxes can no longer be serviced by a vehicle. Just across from Long Canyon Trail, there is limited space between property line and back of curb. For most of the alignment in Dallas the available right-of-way will accommodate the 12-ft. wide sidepath that will be constructed immediately behind the back of the existing curb. There is a 230 linear feet (LF) segment near Timberbluff Rd. where the existing curb is proposed to be relocated into the street about two feet to avoid a private fence. The existing curb line will need to be shifted, and vehicular lanes reduced (refer to Exhibit D-1). Curb adjustments will be applied to both sides of the roadway to maintain the existing road centerline. From that point to Cedar Hill/Dallas City limit near Sorcey Rd. the sidepath will be located along City of Dallas-owned property on the west side of Country View Rd. It will not require any roadway curb adjustments and will be within the existing right-of-way.

Project Stakeholders

- Coordination between City of Cedar Hill and City of Dallas
- Private Property Owners
- US Postal Service

Alignment and Engineering Constraints

- Final approvals and curb adjustments from City of Dallas
- Mailbox relocation coordination with private property owners on Country View Rd.
- Coordination between City of Cedar Hill, to ensure project will be constructed on a similar timeframe with future improvements south of Sorcey Rd.
- The 900 LF segment of Trail A on southbound Country View Rd. from Mountain View Parkway will require driveway reconstruction outside the existing right-of-way to accommodate the sidepath
 - Consider alternative of no parking on the road, and sidepath on the road marked as separate lane or shared lane
 - May require the use of mountable curb



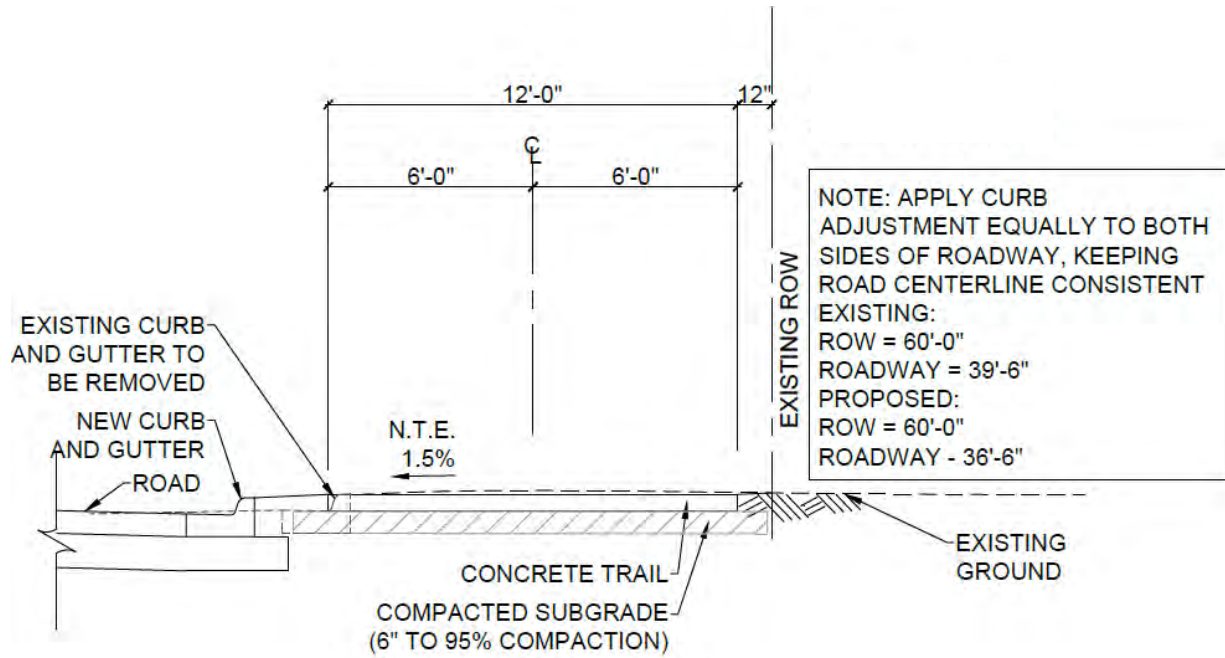

EXHIBIT D-1 – TYPICAL CURB ADJUSTMENT SECTION
N.T.S

Cedar Hill Trail A: Straus Rd. (Cedar Hill/Dallas City limits to New Clark Road)***New Clark Rd. (Straus Rd. to FM 1382)******Trail Alignment***

Trail Segment A will serve as a sidepath along the west side of Straus Rd. from Cedar Hill/Dallas city limit near Sorcey Rd. to New Clark Rd. As Trail A continues south in Cedar Hill, it is nearby the Summit Regional Water Storage Facility where several small street trees will need to be removed and residential side fences between Taylor St. and McAlister St. will likely have to be removed and replaced to accommodate sidepath construction. Space limitations between back of curb and private property along this corridor will require some property right of way acquisition. The specific areas requiring right-of-way acquisition are east of McAlister St., west of Taylor St., and between Beard Dr. and Miller Dr. In addition, the topography is steep beyond the back of curb in multiple areas along this stretch of Straus Rd. and a retaining wall with a guardrail is required to uphold the soil and allow for proper slopes and clearance to build a 12-foot sidepath (refer to Exhibit CH-1, and CH-2). Cedar Ridge Nature Preserve is adjacent to this corridor and is a great amenity and attraction for use of this sidepath. Further coordination and approval will be required with Texas Parks and Wildlife Department.

At Old Straus Rd., the sidepath crosses the roadway and travels along the east side of New Clark Rd. south and crosses FM 1382 and connects with the existing FM 1382 sidepath along the west side of the highway. The first 400 feet south along Old Straus Rd. has very steep grades and is adjacent to rock outcropping. Further investigation would be needed to explore the safety of the sidepath proximity to the rock outcropping.

Project Stakeholders

- City of Cedar Hill
- Private Property Owners
- Texas Parks and Wildlife Department
- Summit Regional Water Storage Facility

Alignment and Engineering Constraints

- Final approvals and easements from private property owners along Straus Rd. due to limited space between property line and face of curb. The specific areas requiring right of way acquisition are east of McAlister St., west of Taylor St., and between Beard Dr. and Miller Dr.
- Coordination with City of Dallas ensuring project will be constructed on a similar timeframe with improvements north of Sorcey Rd.
- Retaining wall will need additional design and engineering along Straus Rd.
- Navigating existing topography changes adjacent to Straus Rd.

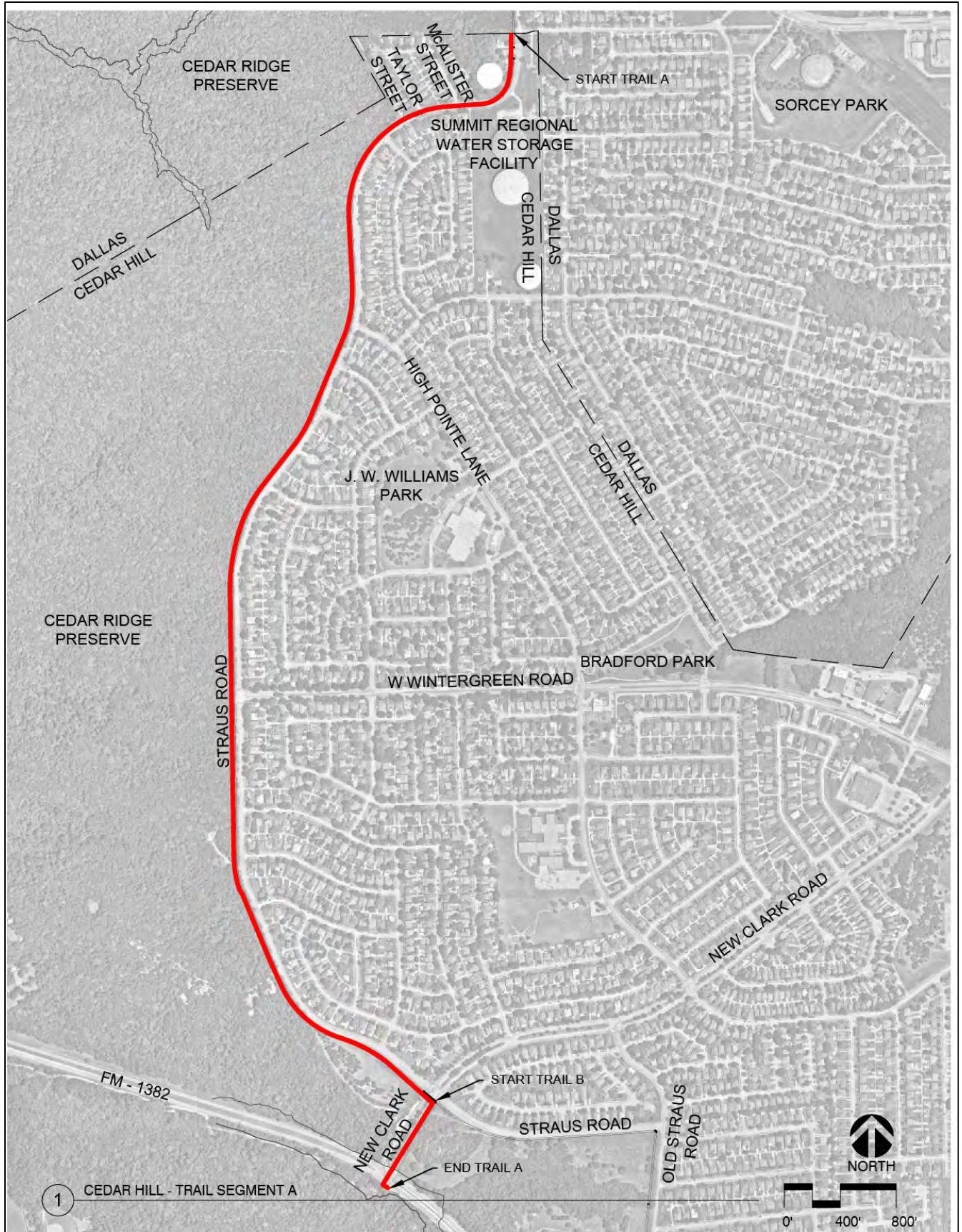

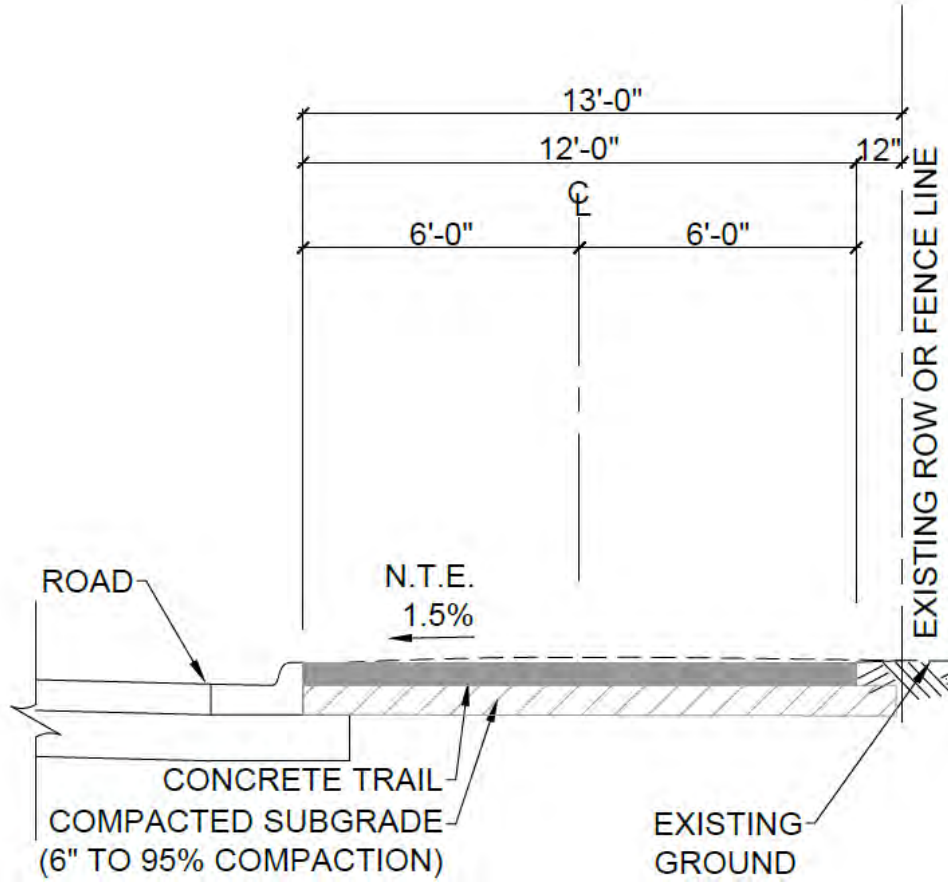

EXHIBIT CH-1 – ADJACENT TO ROADWAY TYPICAL SECTION
N.T.S.

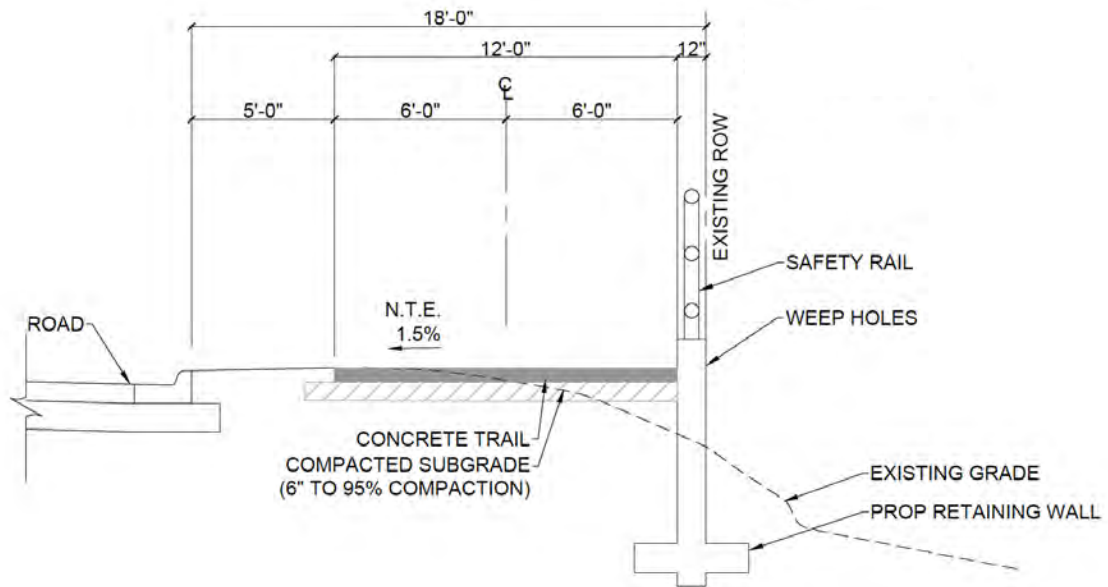

EXHIBIT CH-2 – ROADWAY TYPICAL SECTION WITH RETAINING WALL
N.T.S.

Cedar Hill Trail B: Straus Road (New Clark Road to Old Straus Rd. & FM 1382)***FM 1382 (Old Straus Rd. to Pleasant Run Road)******Trail Alignment***

Trail Segment B will serve as a sidepath starting at the intersection of Straus Rd. and New Clark Rd., eastbound along the south side of Straus Rd. to Old Straus Rd. When the vacant property along Straus Rd. is developed, an easement will be required due to limited space and existing utilities within street right-of-way along this corridor. Trail B will continue from Straus Rd. southbound along the west side of Old Straus Rd. to FM 1382. Along the southern half of Old Straus Rd., the sidepath will cross five private driveways which will require Americans with Disabilities Act of 1990 (ADA) ramps to maintain ADA accessibility throughout the sidepath. At FM 1382 the sidepath parallels FM 1382 on the north/east side to Pleasant Run Rd. and will be in the TxDOT right of way of FM 1382. The sidepath will be adjacent to a drainage swale that will require adjustments to ensure water drains away properly. Also, at the corner of Pleasant Run Rd. and FM 1382 an existing storm water outfall will require some grading around the existing headwall.

Project Stakeholders

- City of Cedar Hill
- Private Property Owners
- Hillcrest Baptist Church
- Franchise Utility Owners
- TxDOT

Alignment and Engineering Constraints

- Trail B alignment is located within the existing street rights-of-way
- Final approvals and easements from Private Property Owners
- Navigating existing drainage courses and floodplain requirement
- Coordinate turn lane expansion along the northeast side of Pleasant Run Rd. and FM1382

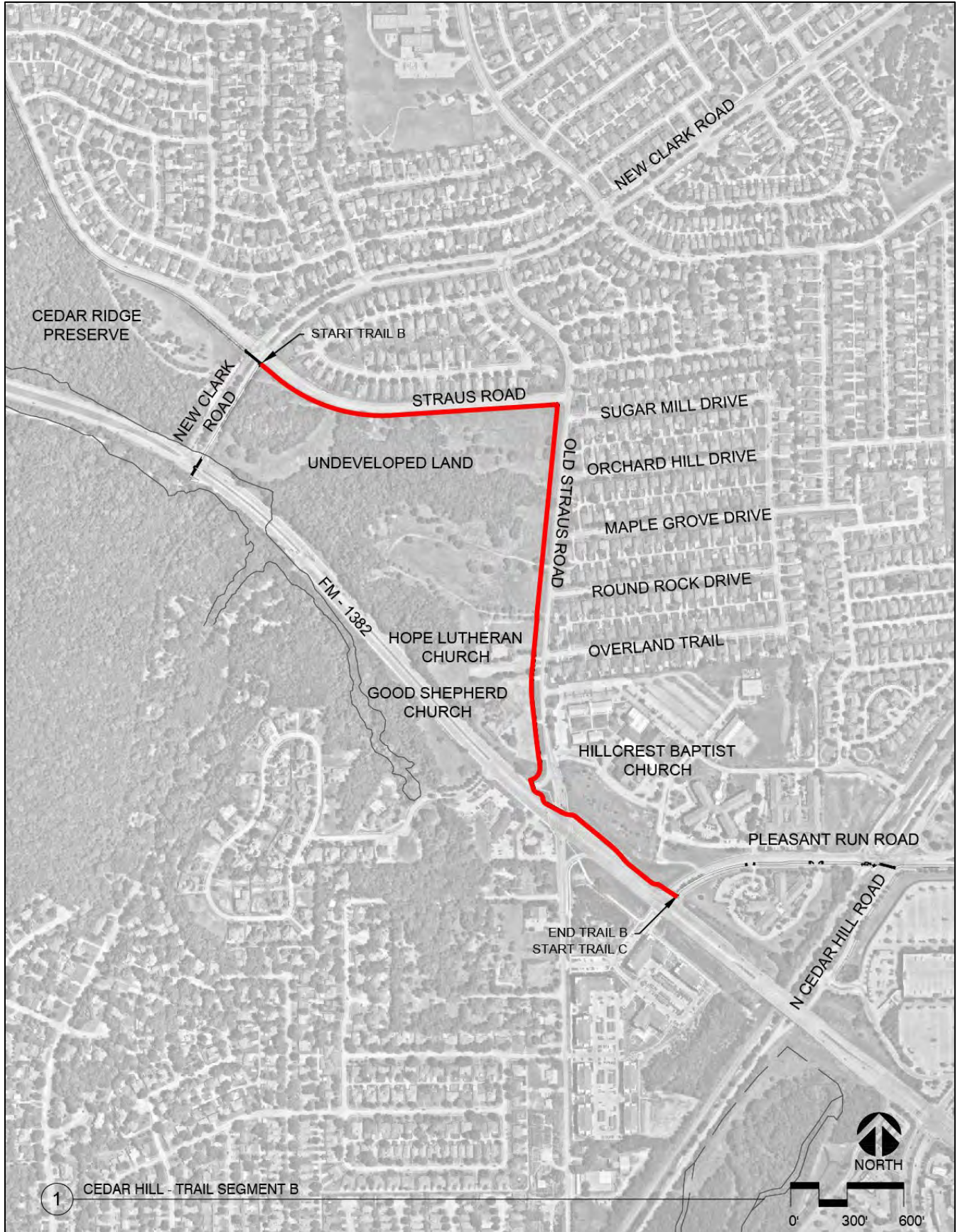

1 CEDAR HILL - TRAIL SEGMENT B

Cedar Hill Trail C: (Pleasant Run Road from FM 1382 to Joe Wilson Road)***Trail Alignment***

Trail Segment C will serve as a sidepath from the corner of FM 1382 and Pleasant Run Rd. and continue along the south side of Pleasant Run Rd. to Joe Wilson Rd. This segment has many drives that require crosswalks and ADA ramps to meet ADA compliance requirements. Existing low retaining walls will need to be removed and reconstructed to accommodate a 12-foot sidepath along Pleasant Run Rd. Some existing trees may also be impacted with this design, and tree mitigation will need to be explored when the trees are removed. There is an existing at-grade sidewalk across BNSF Railway which will be replaced with a sidepath with an at-grade crossing at the BNSF Railway rail line at the southwest corner of Cedar Hill Rd. and Pleasant Run Rd. Further approval and requirements will need to be coordinated with the BNSF Railway company.

An independent pedestrian bridge will be constructed parallel and on the south side of the existing Pleasant Run Rd. vehicular bridge where two 140-ft. prefabricated Keystone Continental Pedestrian Steel Truss Bridges from Contech will be separated by 20-ft. columns. The proposed shared use path bridge will be a two-span bridge approximately 240 linear feet long with 16 feet of deck width (12-ft. width plus 2-ft. shy zones on each side) such as a TxDOT style girder bridge. The span lengths and girder type are intended to match the existing vehicular bridge. As-built information was not readily available, but the assumption was Tx46 girders were used based on apparent span length and girder spacing from information on Google Earth.

The abutments for the existing vehicular bridge sit on top of drilled shaft walls and the new bridge will similarly need to sit on top of the drilled shaft wall abutments, due to the span lengths and girder types. Increasing span lengths in an attempt to grade out would require a deeper girder (Tx54, eight inches deeper than the assumed Tx46), which in turn would not allow existing vertical clearance (18-foot) to be maintained without significantly raising the bridge profile.

Since this trail bridge will be constructed over US 67 and will require abutments in the center highway median, road closures and night work will be required. refer to Appendix B for concepts and discussions with TxDOT staff.

On the east side of US 67 the sidepath will continue along the south side of Pleasant Run Rd. to Joe Wilson Rd. where it connects to an existing sidepath. Limited space due to utilities will require property easement acquisition to allow for a 12-foot wide sidepath.

Project Stakeholders

- City of Cedar Hill
- Private Property Owners
- BNSF Railway
- TxDOT
 - Permitting
 - Approved Traffic Control Plan
 - Proposed abutments in highway median
 - Highway closures and night work requirements

Alignment and Engineering Constraints

- Final approvals and easements from TxDOT and Private Property Owners
- Coordination with TxDOT on the location and design requirements as the shared use path bridge
- Coordination with BNSF Railway on design requirements for an at-grade railroad crossing at southwest corner of Pleasant Run Rd. and Cedar Hill Rd.

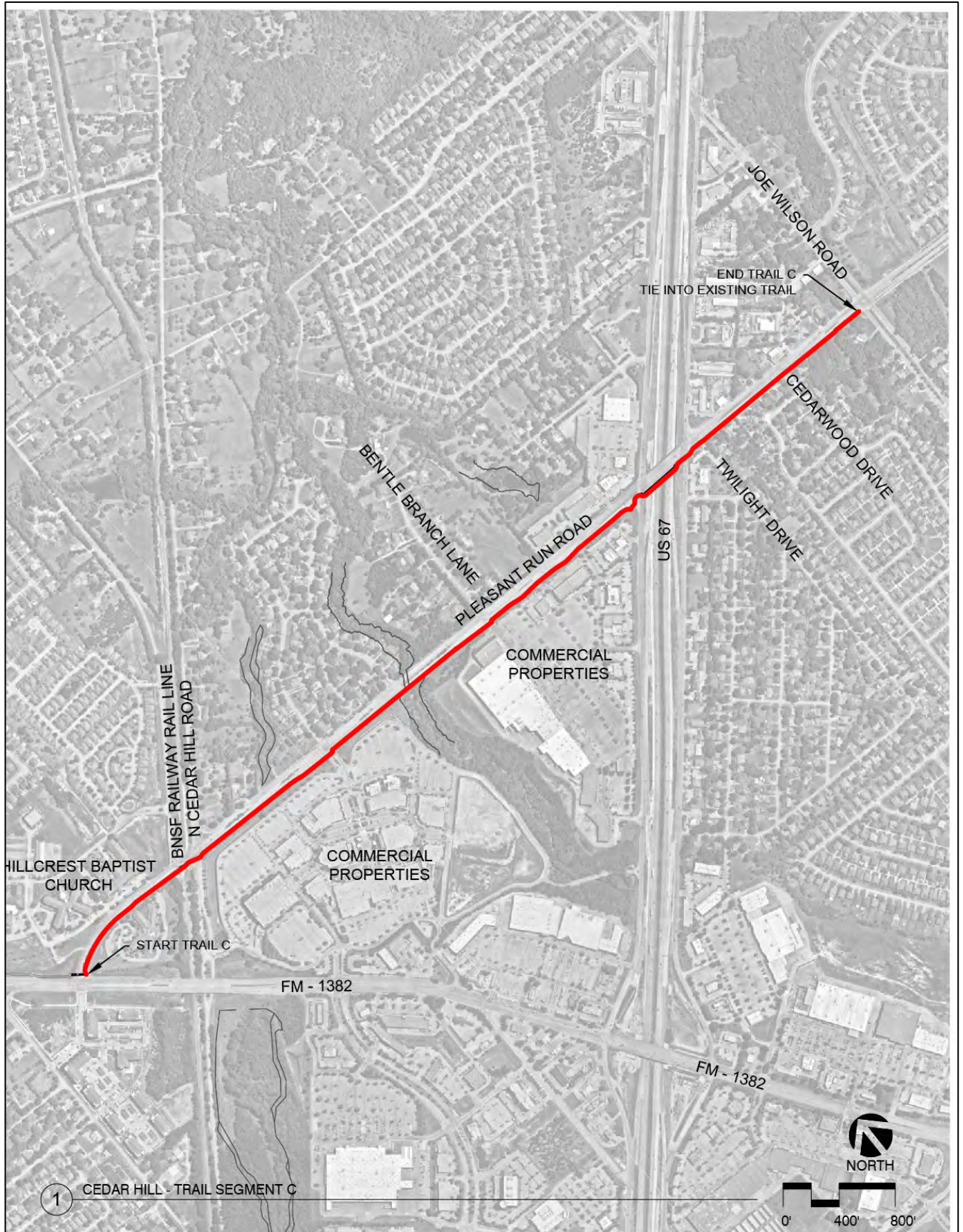

I. CEDAR HILL US 67 CROSSING – CONCEPT C



CONCEPT GOALS

- 1 PROVIDE A SAFE PEDESTRIAN EAST-WEST CROSSING
- 2 UTILIZE AVAILABLE SPACE
- 3 MINIMIZE PEDESTRIAN AND VEHICULAR CONFLICTS

CONCEPT SOLUTION

- 1 INTEGRATES THE PROPOSED US 67 WIDENING
- 2 INTEGRATE THE FUTURE US 67 TEXAS U-TURN
- 3 UTILIZES THE EXISTING SPACE ALONG TXDOT ROW TO CREATE THE APPROACHES TO THE 370' BRIDGE CROSSING
- 4 UTILIZE A DEDICATED PEDESTRIAN BRIDGE ACROSS US 67 ON THE SOUTH SIDE CROSSING

11

Duncanville Trail A: (Ten Mile Creek from Main Street to Waterview Park)***Trail Alignment***

Trail Segment A will serve as a sidepath starting at the corner of Daniieldale Rd. and Main St. and travel as a sidepath southward along the east side of Main St. to Hornet Branch Creek (refer to Exhibit DU-1). This segment will serve as a connection between the funded on-street facility on Daniieldale Rd. to Waterview Park. The sidepath will then traverse along the north side of Hornet Branch Creek and Ten Mile Creek meandering from Main St. to a crossing under US 67 and continuing eastward to Waterview Park.

Erosion adjacent to an existing utility line at US 67 will need to be remediated by TXDOT. Currently the pipe has failed and is eroding the embankment of the US 67 at Ten Mile Creek Bridge. The erosion issue will be addressed by TxDOT (refer to Appendix B for concepts and discussions with TxDOT). The sidepath then bends and follows a Trinity River Authority of Texas (TRA) utility easement and is proposed to cross an existing heavily eroded channel that should be repaired before the sidepath is installed. The erosion appears to be at the outfall of the right-of-way ditches adjacent to US 67 which has exposed major utilities.

The sidepath requires retaining walls on both sides for the portion that is undercrossing US 67. Detailed survey and hydrologic analysis of this portion of Ten Mile Creek will be necessary to determine final retaining wall needs. If water surface elevations allow, the alignment may be adjusted to minimize the needs for retaining walls. Coordination with TxDOT, USACE and TRA may also be necessary during the design process as shown in Exhibit DU-2.

On the east side of US 67, the sidepath continues along a utility corridor before crossing Ten Mile Creek, requiring a pedestrian bridge with a boardwalk to cross the existing tributary. The connection to Waterview Park is a proposed pedestrian bridge running perpendicular to the contours of Ten Mile Creek. The portion of the sidepath leading to the ridge from the west crosses underneath US 67 bridges along the north bank of Ten Mile Creek, then through a wooded area between residential neighborhoods. The sidepath extends to the east, crossing one residential lot then bends to cross the creek perpendicularly and then ties into the north side of Waterview Park and connects to the existing sidepath within the Park. The sidepath alignment has been revised at the suggestion of Duncanville staff to cross only one residential property in the undevelopable portion of their property located in the flood plain and outside of their fenced in back yard.

The proposed pedestrian bridge type is a single-span, 110-foot, prefabricated truss bridge sitting on cast-in-place concrete abutments. The bridge structure will transition to a 115 LF boardwalk with cast-in-place abutments. The total width of the bridge is 16 feet.

The proposed pedestrian bridge model and manufacturer is Keystone Continental Pedestrian Steel Truss Bridge from Contech. For low creek crossings such as the one proposed, this type of pedestrian bridge is commonly used instead of a TxDOT-style girder bridge due to the superstructure type, ease of installation, and aesthetics. The superstructure of this bridge is above the deck, versus deck with beams/girders like a TxDOT bridge, so there is greater freeboard. After the boardwalk, the sidepath will continue at grade and will connect to the main sidepath around Waterview Park.

Project Stakeholders

- City of Duncanville
- Private Property Owners
- Trinity River Authority of Texas
- US Army Corp of Engineers
- TxDOT

Alignment and Engineering Constraints

- Final approvals and easements from Private Property Owners
- Coordination with TxDOT on the location and design requirements as the sidepath traverses underneath US 67
- Design and engineer Ten Mile Creek Crossing and navigate boardwalk crossing of tributary of Ten Mile Creek
- The alignment of the sidepath and bridge at this location was chosen to minimize the amount of encroachment into nearby property, and to also allow the bridge to cross perpendicular to the creek

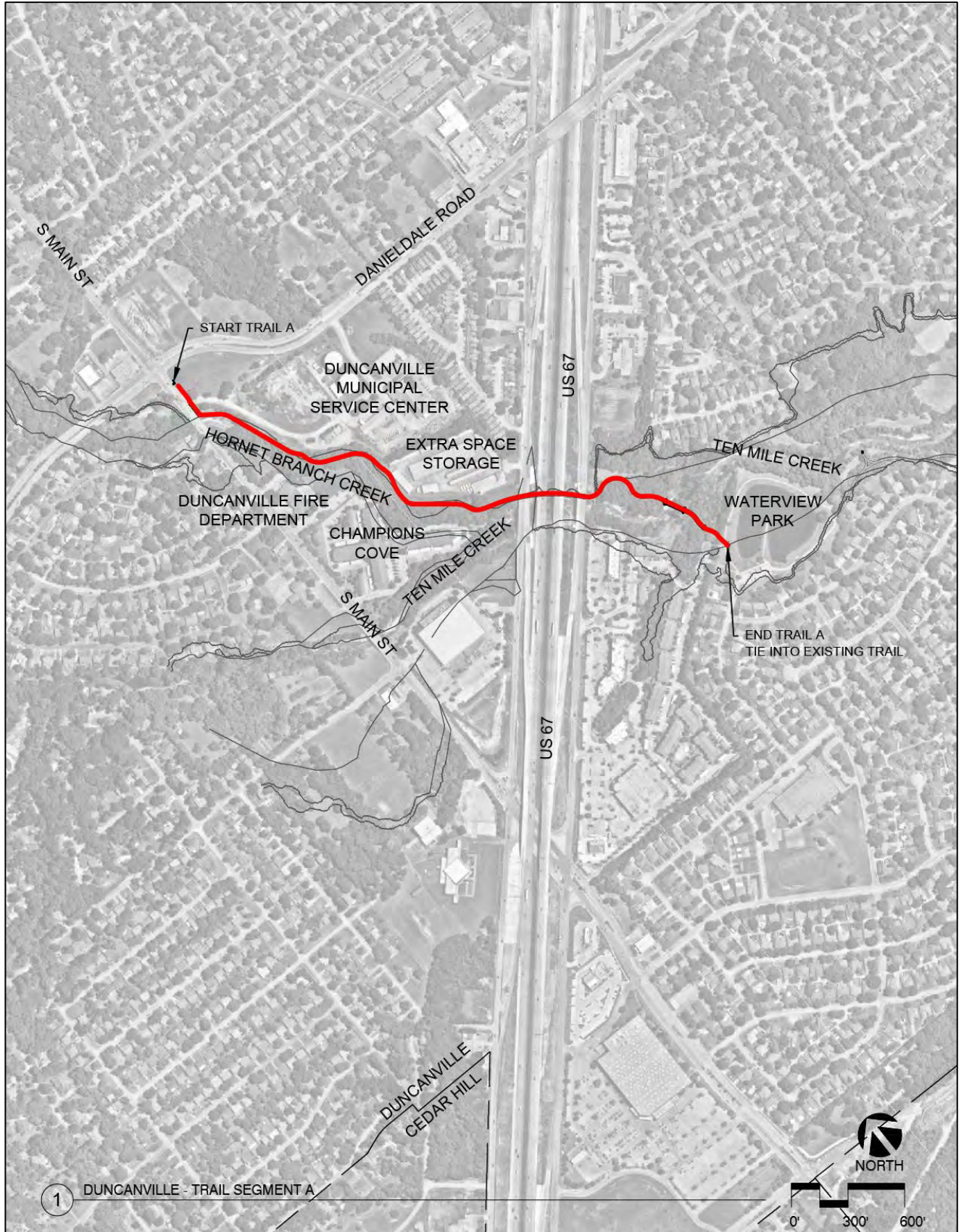

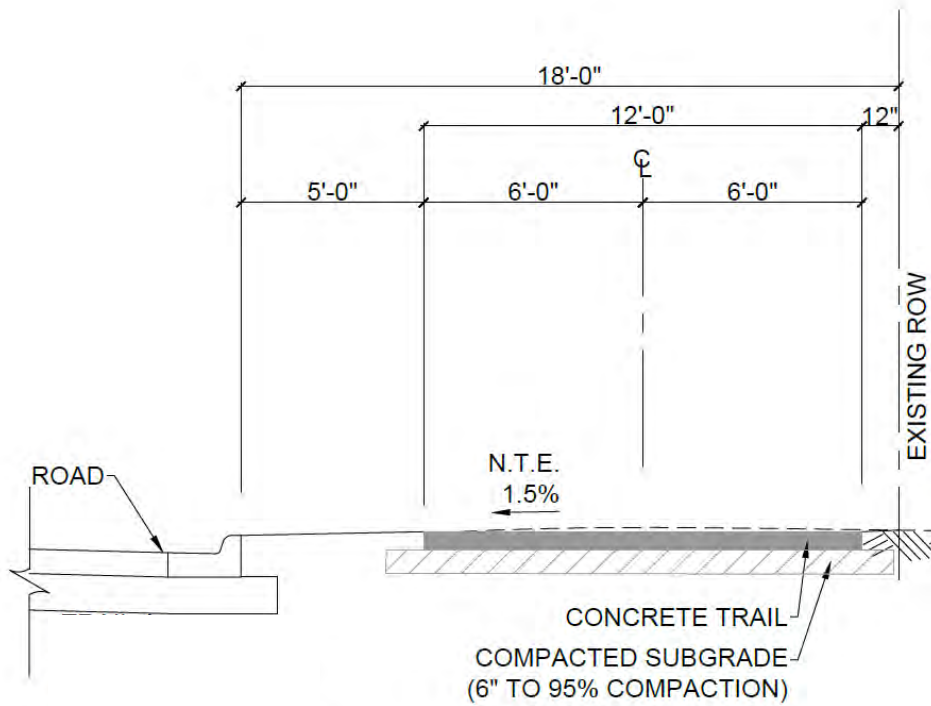

EXHIBIT DU-1 – ROADWAY TYPICAL SECTION

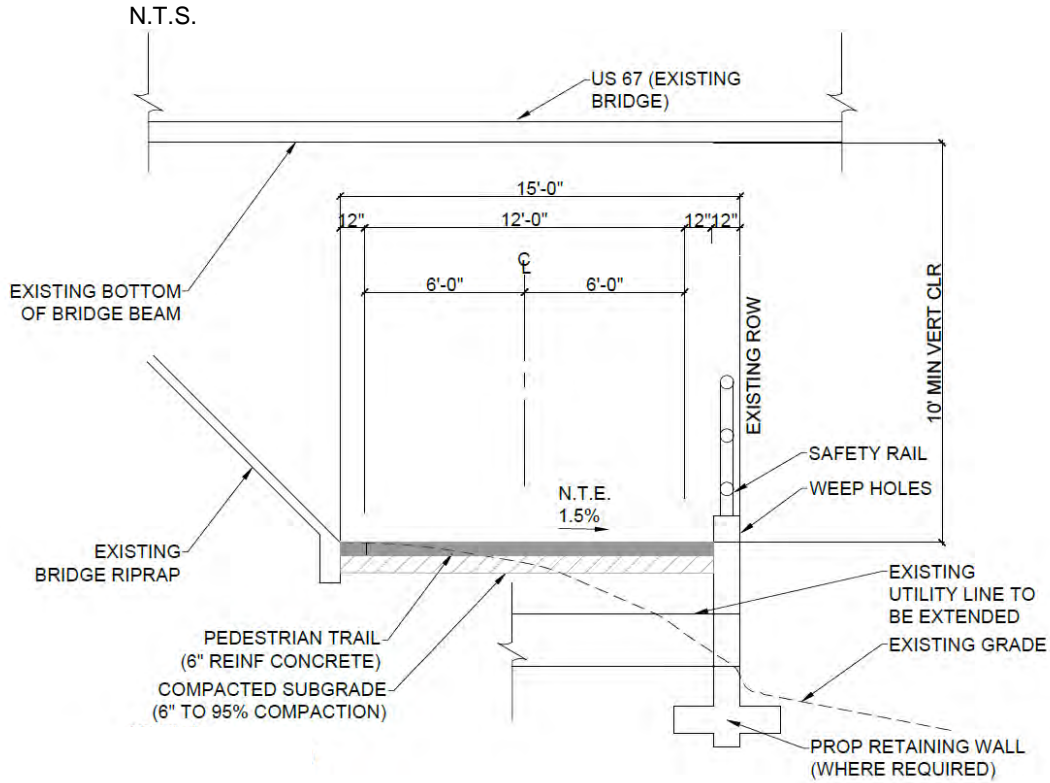

EXHIBIT DU-2 – UNDER US 67 CROSSING TYPICAL SECTION

N.T.S

Duncanville Trail B: (Along Ten Mile Creek from Waterview Park to W. Wintergreen Road)***Trail Alignment***

Trail Segment B will serve as a sidepath starting at the southeast corner of Waterview Park and follow along the south side of Ten Mile Creek southward to Wintergreen Rd. The sidepath will connect to the proposed sidepath connection between Waterview Park and Marcus Harrington Park that is currently being designed and constructed by the City of Duncanville. Tree mitigation will need to be explored moving forward along this corridor due to existing dense vegetation. The sidepath will travel along City of Duncanville owned properties, except along one large property owned by Duncanville Independent School District (ISD).

Project Stakeholders

- City of Duncanville
- Private Property Owners
- Duncanville ISD

Alignment and Engineering Constraints

- Final approvals and easements from Private Property Owners
- Coordination with City on the location and design of sidepath connection between Waterview Park and Marcus Harrington Park

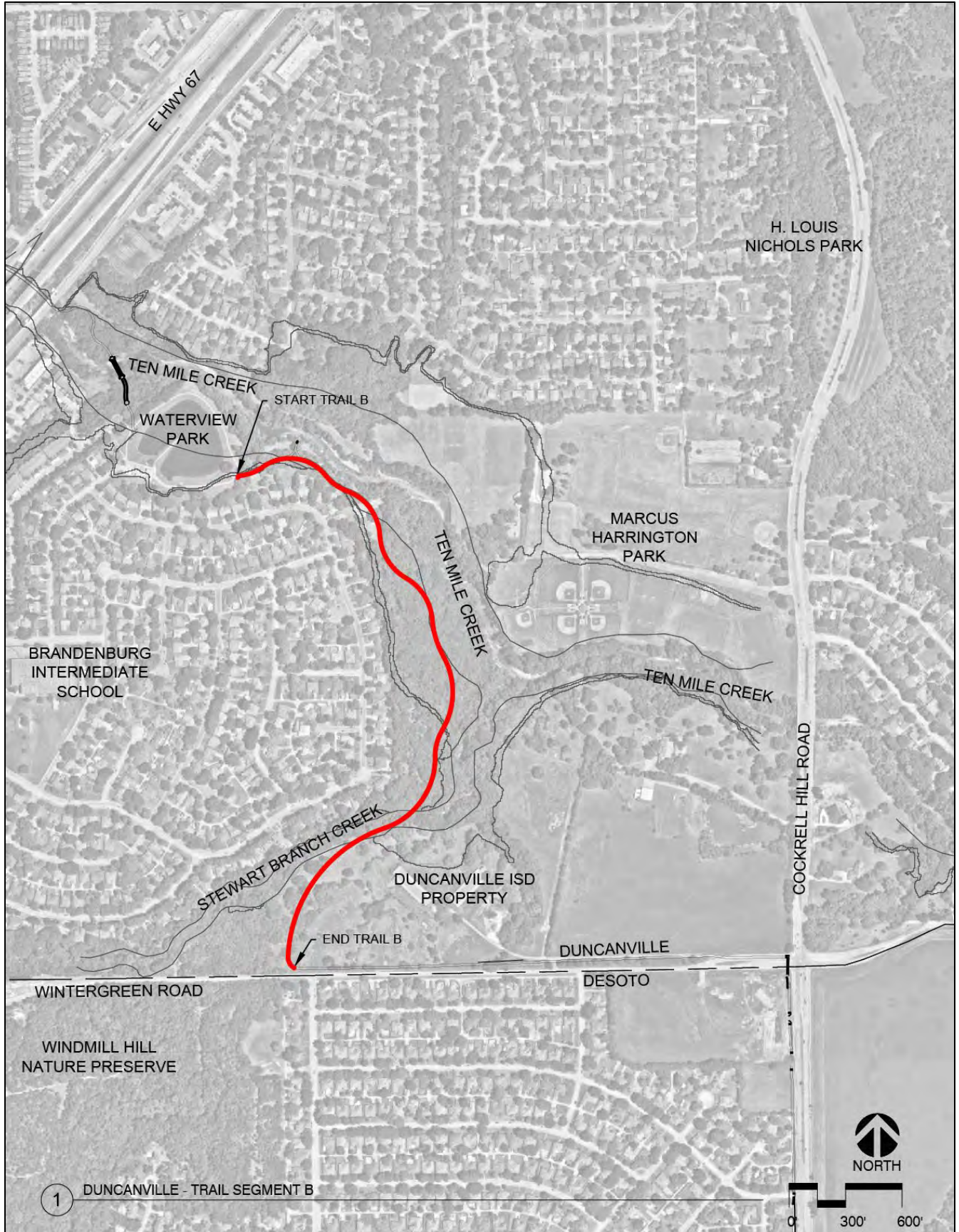

1 DUNCANVILLE - TRAIL SEGMENT B

Duncanville Trail C: (Wintergreen Road from Ten Mile Creek to Cockrell Hill Road)***Trail Alignment***

Trail Segment C will serve as a sidepath along the north side of Wintergreen Rd. in Duncanville from Ten Mile Creek east to Cockrell Hill Rd. The sidepath is anticipated to be included in the future widening of Wintergreen Rd. west of Cockrell Hill Rd. Currently Wintergreen Rd. has been widened approximately 300 linear feet to east and west of the Cockrell Hill Rd. intersection. Along this segment one private drive will be crossed and will require further coordination in future design phases (refer to Exhibit DU-1).

Project Stakeholders

- City of Duncanville
- Private Property Owners
- Duncanville ISD

Alignment and Engineering Constraints

- Final approvals and easements from Private Property Owners
- Coordination with City on the any future widening of Wintergreen Rd.



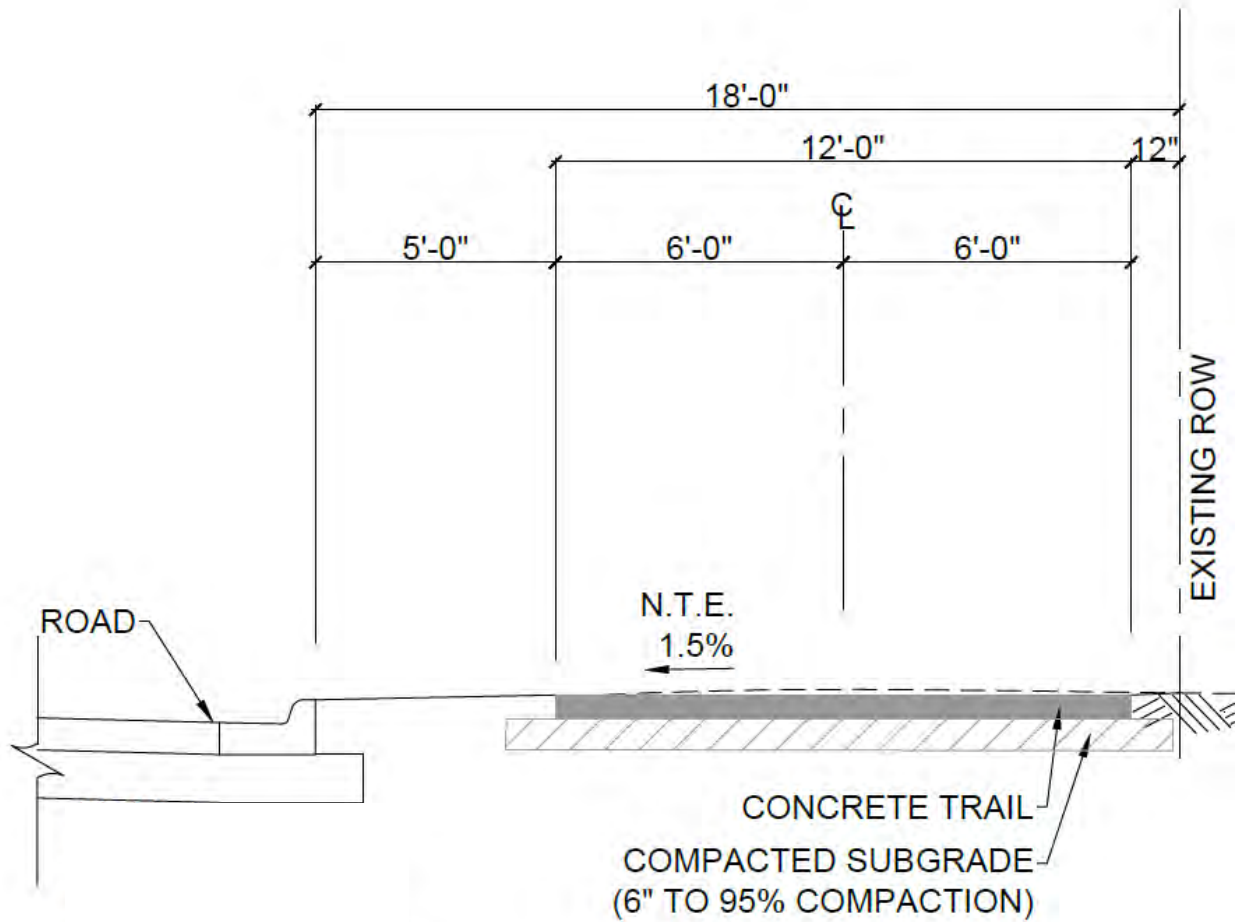

EXHIBIT DU-1 – ROADWAY TYPICAL SECTION
N.T.S.

DeSoto Trail A: (Cockrell Hill Road from Wintergreen Road to Pleasant Run Road)***Trail Alignment***

Trail Segment A will replace an existing sidewalk with a 12-ft. wide sidepath along the west side of Cockrell Hill Rd. in DeSoto from Wintergreen Rd. to Pleasant Run Rd. This alignment has many driveways that require crosswalks and ramps to meet ADA requirements. Existing utilities, fire hydrants, and mailboxes will need to be adjusted within the existing right-of-way to accommodate the 12-ft. wide sidepath. A proposed connection to Windmill Hill Homeowner's Association (HOA) trail along the west side of Cockrell Hill Rd. just south of Rusticwood Dr. will connect to more residential users and make another park connection to Kiva Park.

A retrofit of Cockrell Hill Rd. bridge (over Bee Branch Creek) will ramp onto the bridge and add a concrete bridge barrier to separate vehicular traffic and the new pedestrian and bicycle traffic along the bridge. An existing shoulder on the bridge will be repurposed to be the sidepath, while maintaining the existing sidewalk.

The two-way cycle track will be 12 feet wide allowing for two-way bicycle traffic along the bridge while maintaining the existing sidewalk for pedestrians (refer to Exhibit DS-1).

One residential property just south of Whispering Oaks Dr. on the west side of Cockrell Hill Rd. has a five-foot retaining wall at back of sidewalk allowing no space for a 12-ft. wide sidepath. A pinch point of an eight-foot wide sidepath is proposed for a segment of 24 linear feet.

Project Stakeholders

- City of DeSoto
- Private Property Owners
- US Postal Service

Alignment and Engineering Constraints

- Final approvals and easements from Private Property Owners
- Cockrell Hill Rd. bridge crossing (retrofit)
- Coordination with Windmill Hill HOA for connection to HOA sidepath

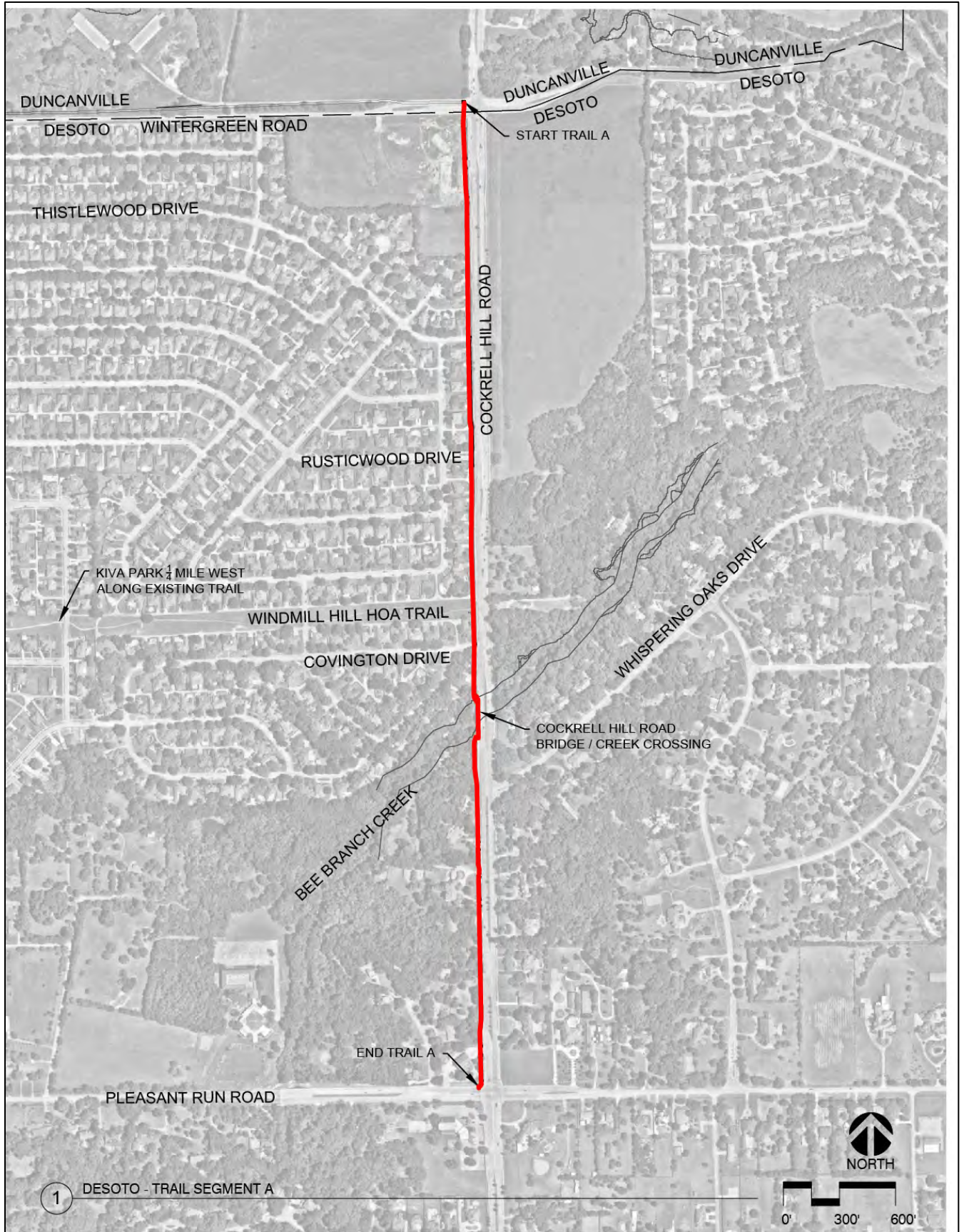

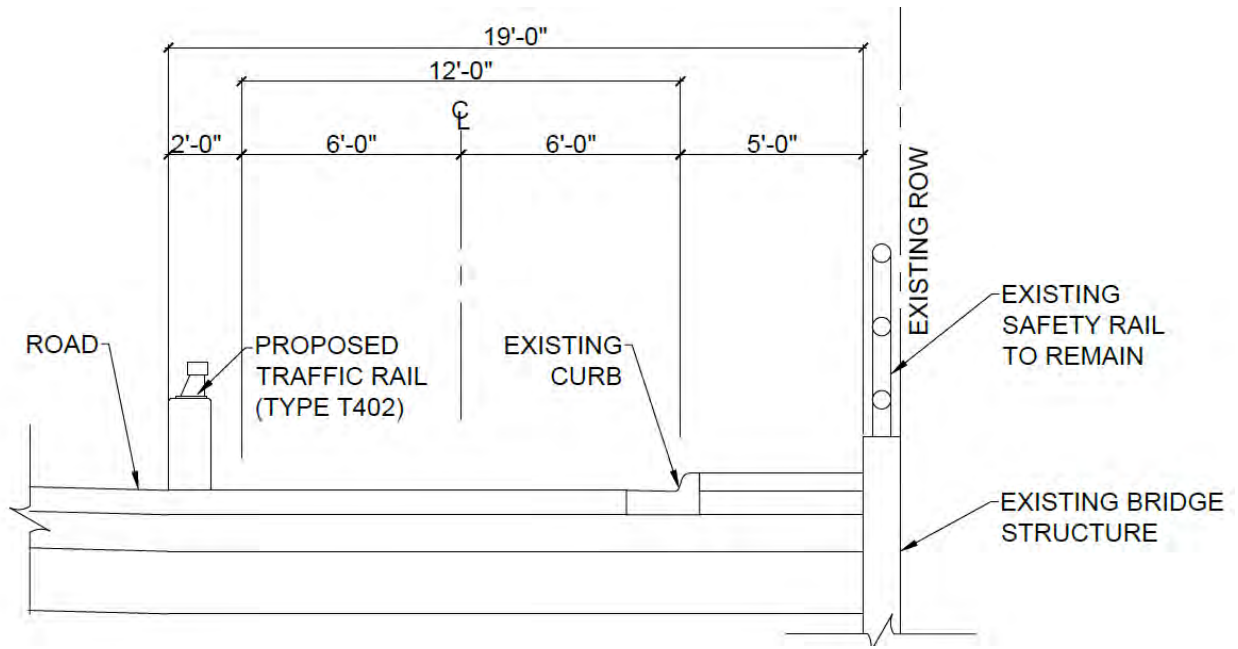

EXHIBIT DS-1 – COCKRELL HILL ROAD BRIDGE TWO-WAY CYCLE TRACK
N.T.S.

DeSoto Trail B: (Westmoreland Road from Daniel Farms Development Trail to Roy Orr Trail)***Trail Alignment***

Trail Segment B will serve as a sidepath on the west side of Westmoreland Rd. from the Daniel Farms development sidepath south to W. Wintergreen Rd. where it will connect with the existing Roy Orr Trail. This alignment has many driveways that will require crosswalks and ramps to meet ADA requirements. There is adequate space to construct the sidepath within the current street right-of-way, however an existing drainage area will need to be adjusted to allow for a 12-foot wide sidepath. The sidepath will cross two legs of the intersection of Wintergreen Rd. and Westmoreland Rd., to the southeast corner. The sidepath will continue as a shared-use path heading eastward along the south side of Wintergreen Rd. and meander around existing trees for approximately 450 feet where it will connect with the existing Roy Orr Trail.

Project Stakeholders

- City of DeSoto
- Private Property Owners

Alignment and Engineering Constraints

- Final approvals and easements from Private Property Owners
- Navigating existing drainage courses and floodplain requirements
- Coordinate with Daniel Farms development to connect to their planned sidepath system



DeSoto Trail C: (Pleasant Run Road from Roy Orr Trail to Polk Street)***Trail Alignment***

Trail Segment C will connect with the existing Roy Orr Trail as a sidepath extension on the north side of Pleasant Run Rd. to Polk St., then extend south along the west side of Polk St. to connect with the existing Roy Orr Trail located approximately 250 feet south of the intersection.

A retrofit of Pleasant Run Rd. bridge will shift the curb to expand the existing sidewalk to a 12-foot-wide shared use path along the bridge (refer to Exhibit DS-2). A center median has eight feet of unused roadway pavement that will accommodate a shift of lanes allowing for the expansion of the existing sidewalk along the bridge. Once across the bridge, due to limited space, many utilities will require adjustment and relocation to accommodate the 12-foot wide sidepath. Space is limited and some utilities will need to be adjusted and / or relocated to allow for a 12-foot sidepath. The sidepath will follow Polk St. to the existing Roy Orr Trail; a five-foot parkway will be existing between edge of sidepath and edge of roadway. The entry point along Roy Orr Trail is very steep and requires adjustments of grades to meet ADA requirements.

Project Stakeholders

- City of DeSoto

Alignment and Engineering Constraints

- Seeking final approvals and easements from Private Property Owners

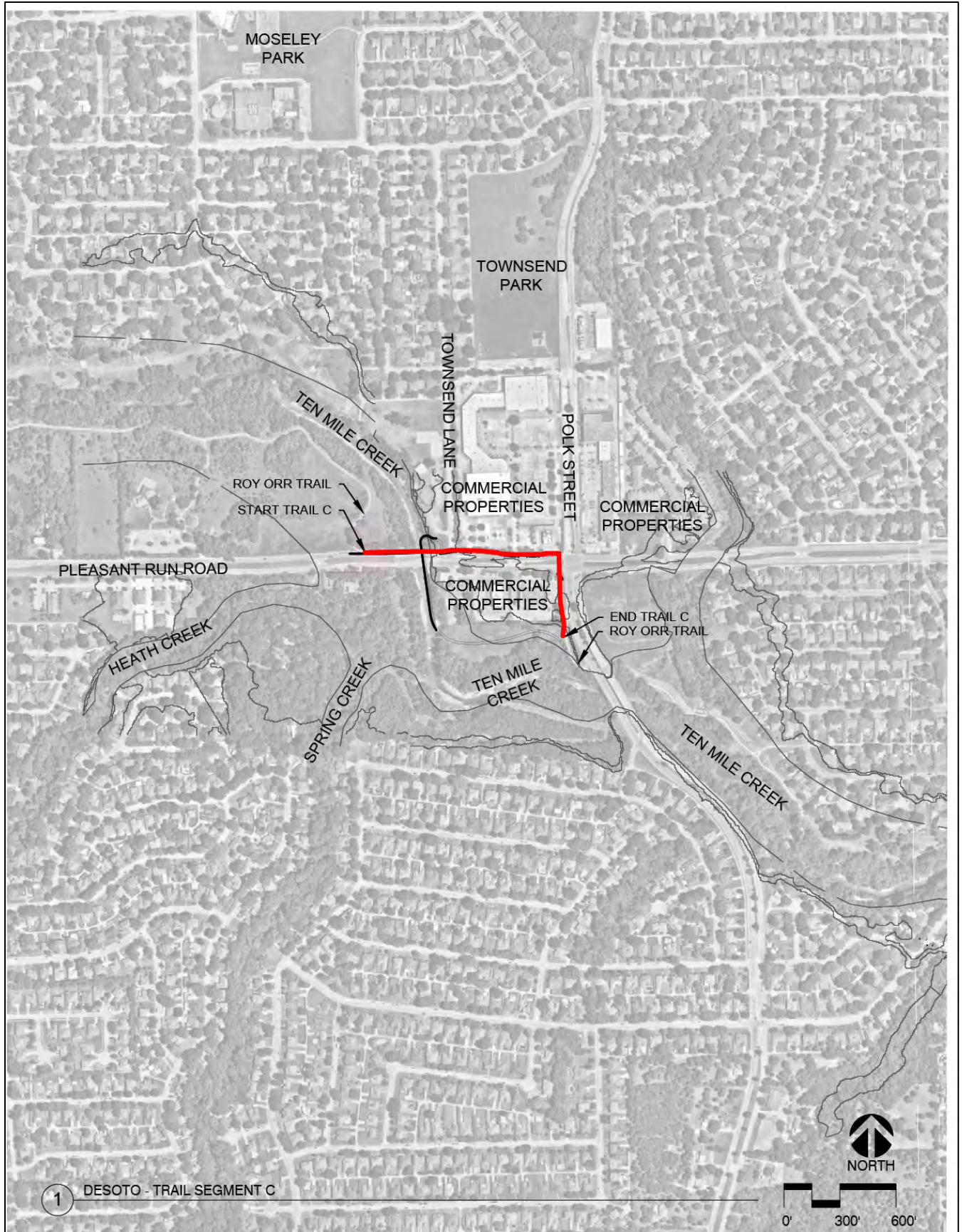

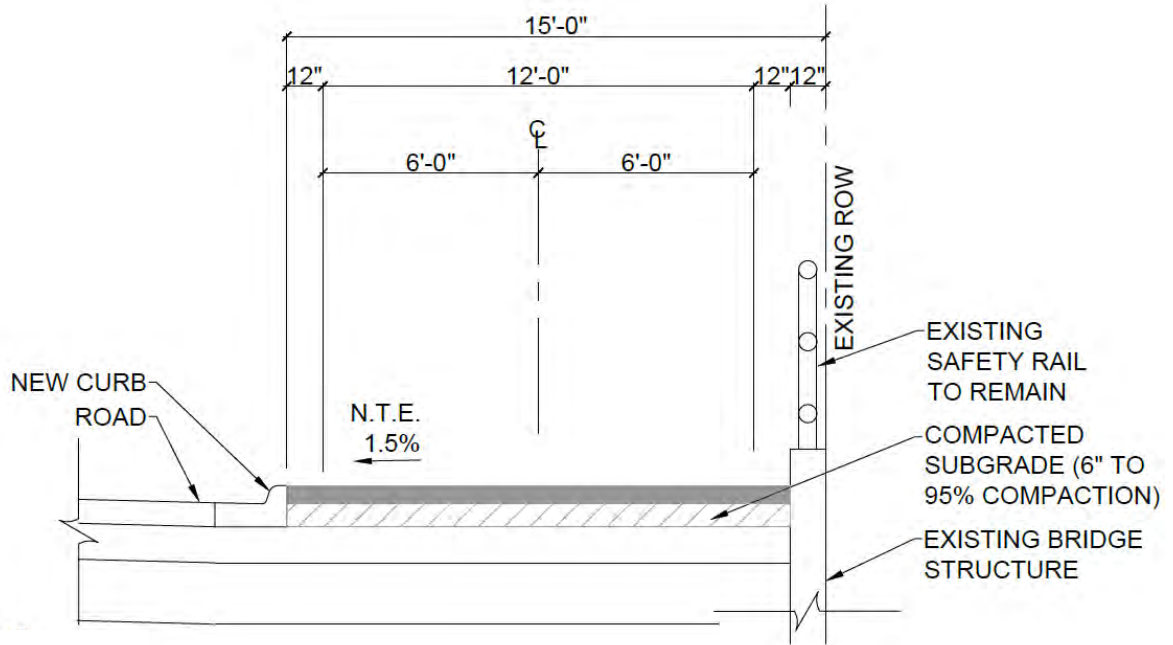

EXHIBIT DS-2 – PLEASANT RUN ROAD BRIDGE TYPICAL SECTION
N.T.S.

DeSoto Trail C Alt: (Pleasant Run Road Undercrossing to Roy Orr Trail)***Trail Alignment***

Trail Segment C Alt is an optional alignment to connect Roy Orr Trail at the intersection of Pleasant Run Rd. and Polk St. The alternative alignment will cross under Pleasant Run Rd. rather than crossing the roadway at-grade at the Polk St. intersection. This alignment does require Pleasant Run Rd. retrofit to accommodate expansion of the sidewalk on the existing bridge. The alternative alignment will serve as a sidepath starting at Pleasant Run Rd. and Townsend Lane and circle around and loop underneath Pleasant Run Rd. to the south side of the roadway and then follow around the south of the commercial properties where it would connect back with the existing Roy Orr Trail along Polk St. The sidepath is proposed to start at the same grade as Pleasant Run Rd. on the east side of the creek and then loop around at four to 4.5 percent descent and then continue south under the Pleasant Run Rd. bridge.

The existing conditions under the Pleasant Run Rd. vehicle bridge over Ten Mile Creek will require special construction considerations that will increase the cost of construction. The existing ground is mostly rock and a clear span of about 10 feet is available from the end of the vehicular bridge riprap to the existing rock face. The top of the rock face is about 15 feet above the water in Ten Mile Creek. These confined spaces may require an extensive amount of difficult work and special equipment to build the proposed sidepath section. The 12-ft. wide sidepath would be benched into the existing concrete riprap/slope protection. The sidepath will then travel underneath Pleasant Run Rd., utilizing a seawall on the creek side with a one-way valve (refer to Exhibit DS-3).

Once across Pleasant Run Rd., the sidepath continues around the commercial properties and connects back to Roy Orr Trail. Along the south side of the commercial properties at the corner of Pleasant Run Rd. and Polk St. have underground utilities running through them. Further investigation will need to happen to locate these lines.

Project Stakeholders

- City of DeSoto
- Private Property Owners
- Utility Companies

Alignment and Engineering Constraints

- Terrain/Minimizing the retaining wall needs
- Final approvals and easements from Private Property Owners

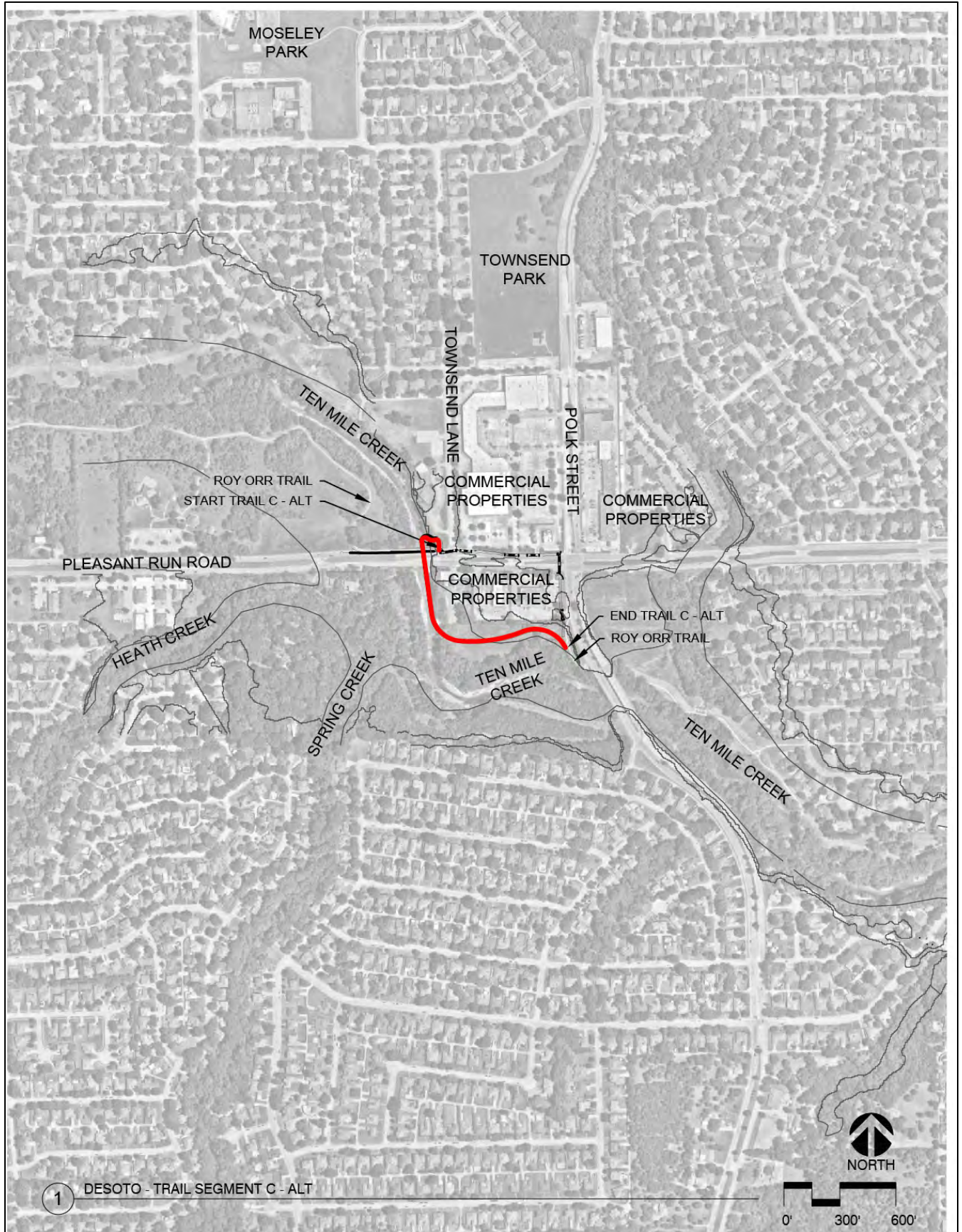

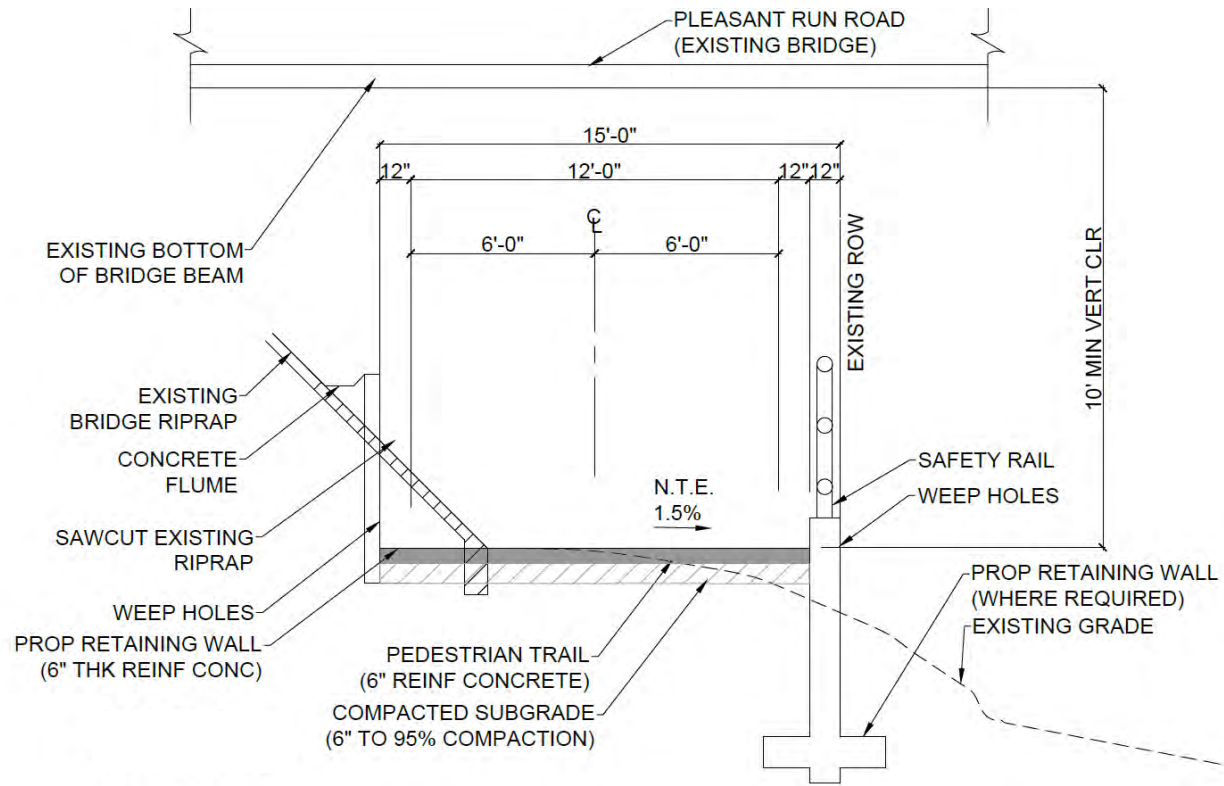

EXHBIT DS-3 – PLEASANT RUN ROAD UNDERPASS TYPICAL SECTION
N.T.S.

DeSoto Trail D: (Meadows Parkway and Plantation Drive)***Trail Alignment***

Trail Segment D will serve as an on-street bikeway connection between existing sections of the Roy Orr Trail. On-street shared lane marking (sharrows) would be installed along Meadows Parkway (approximately 600 feet) and Plantation Dr. (approximately 300 feet) to provide a bikeway connection for Roy Orr Trail. The existing sidewalks along both roadways would be retained for use by pedestrians. A shared lane marking on both roadways was chosen due to the number of residential properties that face this roadway and the amount of on-street parking used by the adjacent homeowners. Multiple signage indicating the start and end of the sharrow and what direction the sidepath continues would be installed to clearly define the bikeway alignment to connect the existing path through the neighborhood. The design proposes shared lane marking signage along with including an additional indicator to vehicles to be aware that cyclists may be present along this stretch of roadway (see Figure 1).

Project Stakeholders

- City of DeSoto

Alignment and Engineering Constraints

- Seeking final approvals from City of DeSoto on pavement markings and signage locations



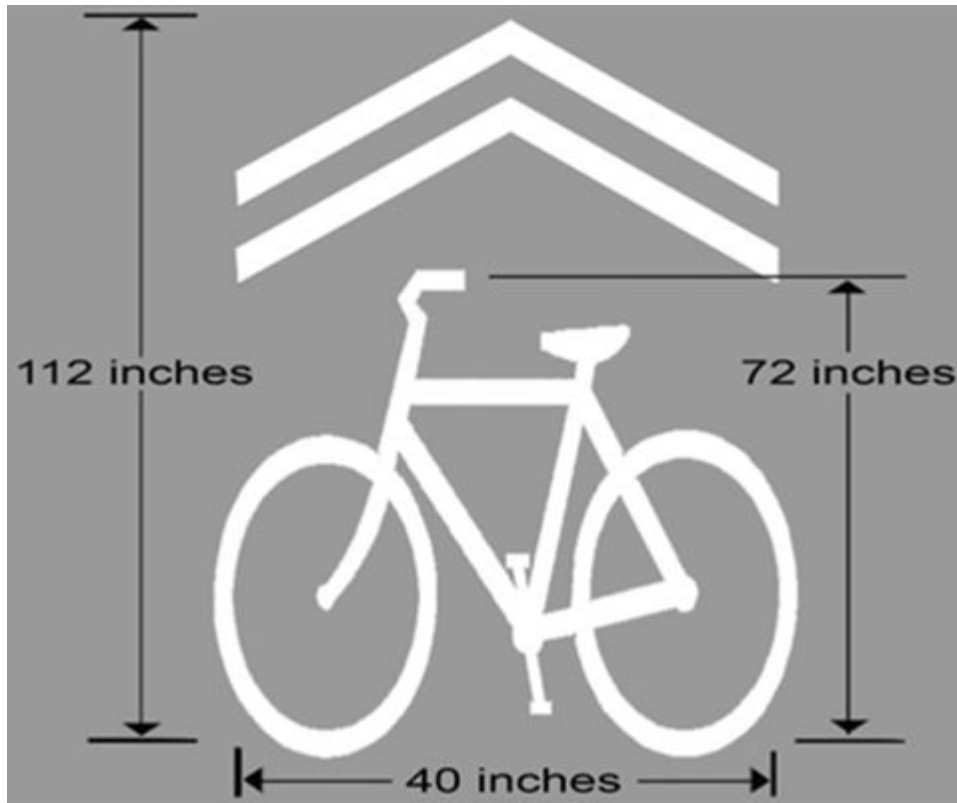

FIGURE 1 – SHARED LANE MARKING
N.T.S.

DeSoto Trail E: (Murphy Hills Park Trail to IH 35E)***Trail Alignment***

Trail Segment E will serve as a sidepath connecting Murphy Hills Park Trail along the east of the residential properties that front onto Alpine Drive and connecting through the existing QuikTrip convenience store property at E. Belt Line Rd. Tree mitigation will need to be explored for this alignment due to the existing dense vegetation east of the residential properties. An easement will be required through QuikTrip property. The sidepath will then cross Ten Mile Creek within TxDOT right-of-way, avoiding any easement on private property.

The alignment of the sidepath east of Ten Mile Creek will cross under the IH 35E southbound frontage road bridge and the elevated IH 35E main lanes. The sidepath will climb the embankment diagonally to meet the IH 35E northbound frontage road with an at-grade crossing at the signalized Belt Line Rd. intersection in the City of Lancaster where it will continue eastward in Lancaster along the north side of W. Belt Line Rd.

The proposed pedestrian bridge is a single-span, 114-foot (likely will utilize 110 or 120-foot-long standard length), prefabricated shared use path bridge sitting on cast-in-place concrete abutments. The total width of the bridge is 16 feet. The type of bridge shown is a Keystone Continental Pedestrian Bridge from Contech, the same as for the Bridge Connection to Waterview Park.

The challenge at this location was during the process of aligning the sidepath to minimize impacts to the QuikTrip property by locating the pedestrian in the TxDOT IH 35E right-of-way and aligned to cross perpendicular to the creek. This was done to minimize bridge length and reduce potential obstacles for hydraulics. The proposed location of the shared use path bridge meets these constraints. The sidepath will require walls on both sides of the sidepath for the portion between the frontage roads. The existing slope is 2:1-3:1 with gabion mattress revetment. The sidepath will require walls with varying heights on both sides of the sidepath for the area underneath IH 35E and coordination with TxDOT will be necessary (refer to Appendix B for concepts and discussions with TxDOT).

The sidepath crossing underneath the IH 35E southbound frontage road will utilize a seawall on the creek side with a one-way valve and ending at the Lancaster/DeSoto city limits (refer to Exhibit DS-3). Crossing underneath IH 35E requires cutting into the embankment and constructing two retaining walls on both sides of the sidepath, preventing the sidepath from flooding.

Project Stakeholders

- City of DeSoto
- City of Lancaster
- TxDOT
- QuikTrip
 - Easement Required

Alignment and Engineering Constraints

- Final approvals and easements from TxDOT and Private Property Owners
- Further coordination with City of Lancaster on construction timeline
- ADA
- Terrain, minimizing retaining wall needs
- Profile to accommodate at-grade crossing of the northbound frontage road at the signalized W. Belt Line Rd. intersection

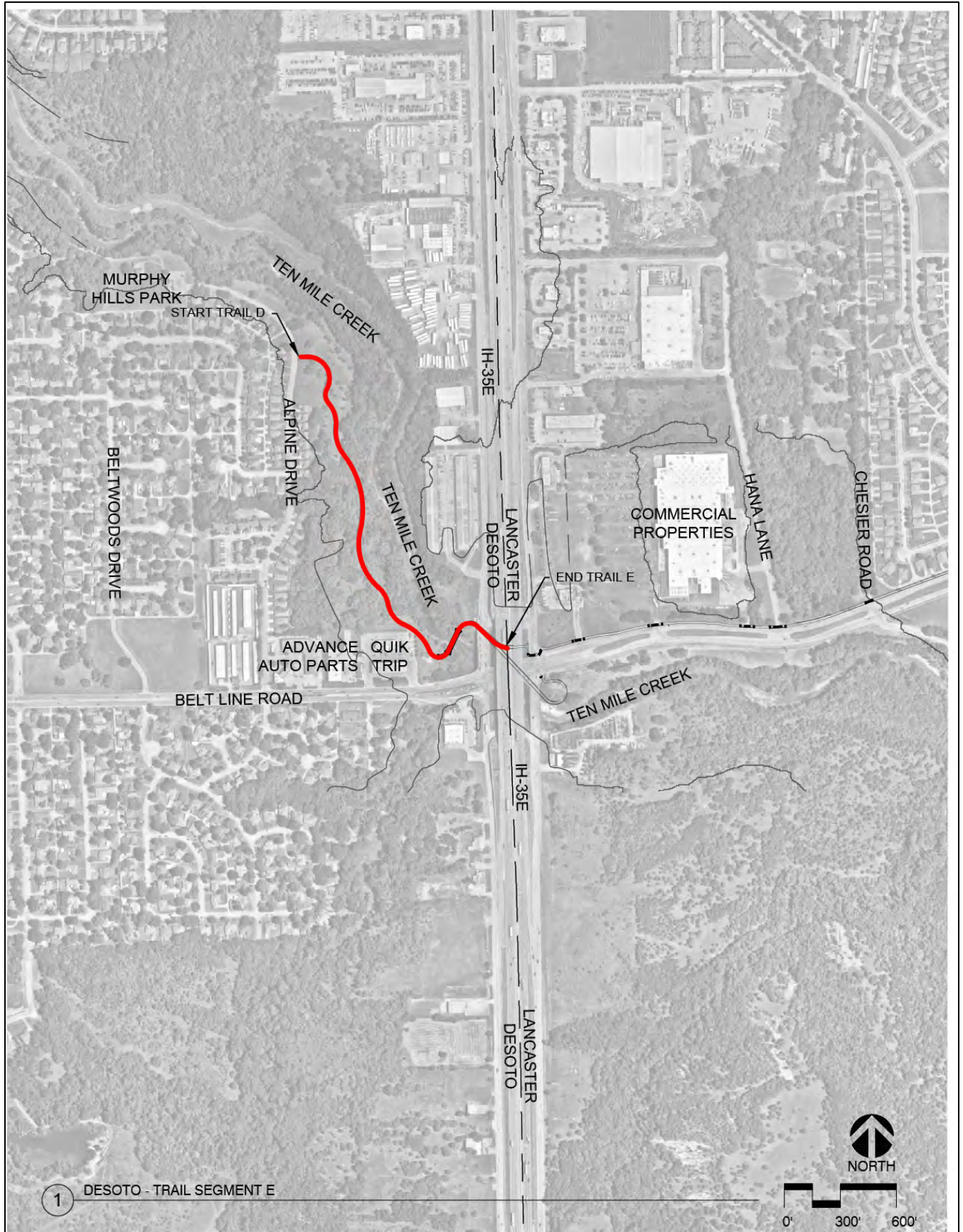

I. IH-35E BICYCLE/PEDESTRIAN CROSSING – CONCEPT A



Lancaster Trail A: Belt Line Rd. (IH 35 E to existing Pleasant Run Hike and Bike Trail)**Trail Alignment**

Trail Segment A will follow the north side of W. Belt Line Rd. from IH 35E northbound frontage road to the existing Pleasant Run Hike and Bike Path near Rosa Parks-Millbrook Elementary School. The sidepath will be a continuation of the IH 35E crossing at the Lancaster/ DeSoto city limits, utilizing a seawall on the creek side with a one-way valve. Crossing underneath IH 35E requires cutting into the embankment and constructing two retaining walls on both sides of the sidepath, preventing the sidepath from flooding (refer to Exhibit L-1). Once up to grade at the northbound IH 35E frontage road, the sidepath will cross the frontage road at the signalized intersection and continue along the north side of Belt Line Rd. (refer to Appendix B for concepts and discussions with TxDOT.)

Near Houston School Rd. there is limited space within the W. Belt Line Rd. right-of-way to accommodate the replacement of the existing sidewalk with a 12-ft. wide sidepath. Along W. Belt Line Rd., the outside vehicle lane curb and the inside median curb would be adjusted thus keeping all drive lanes consistent along Belt Line Rd. (refer to Exhibit L-2). East of Palomino Drive, the roadway curb will remain, and the sidepath will continue (refer to Exhibit L-3), then connect to the existing sidewalk connecting Belt Line Rd. to Pleasant Run Hike and Bike Trail near Rosa Parks-Millbrook Elementary School.

Project Stakeholders

- City of Lancaster
- City of DeSoto
- TxDOT
- Private Property Owners

Alignment and Engineering Constraints

- Final approvals and easements from TxDOT and Private Property Owners
- Further coordination with City of DeSoto on construction timeline for the IH 35E crossing



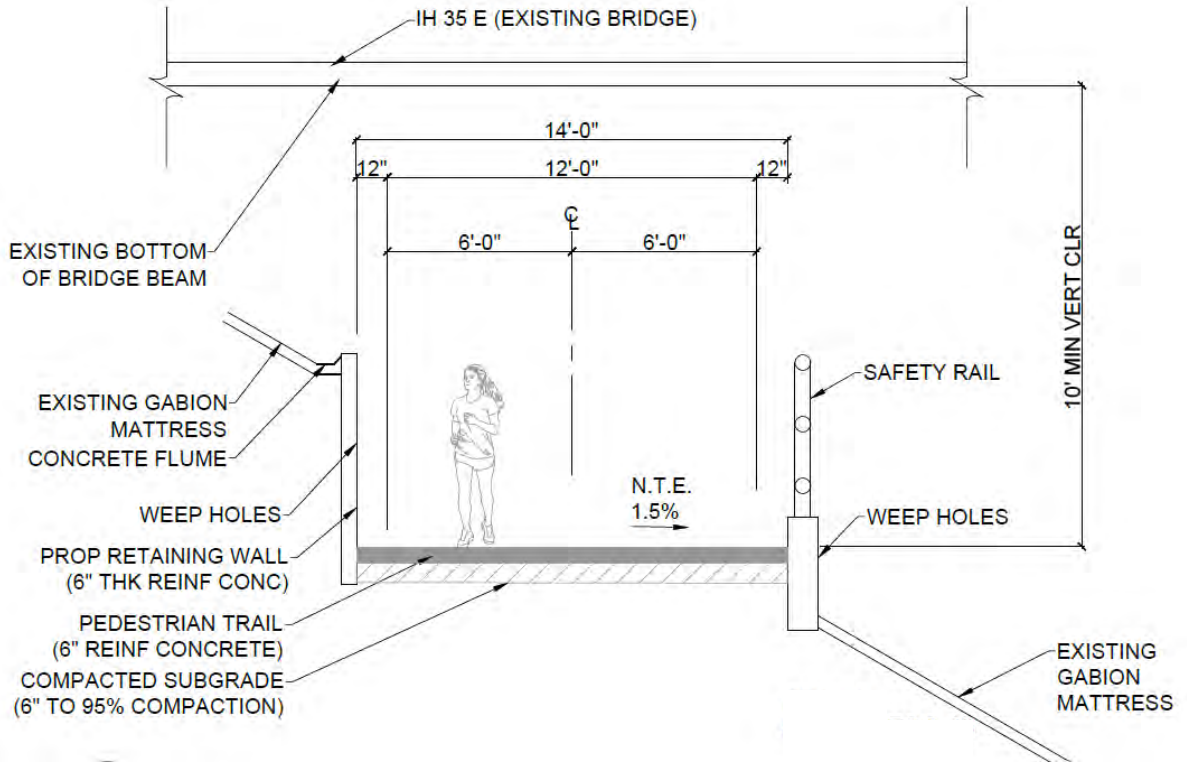

EXHIBIT L-1 – IH 35E UNDERPASS TYPICAL SECTION
N.T.S.

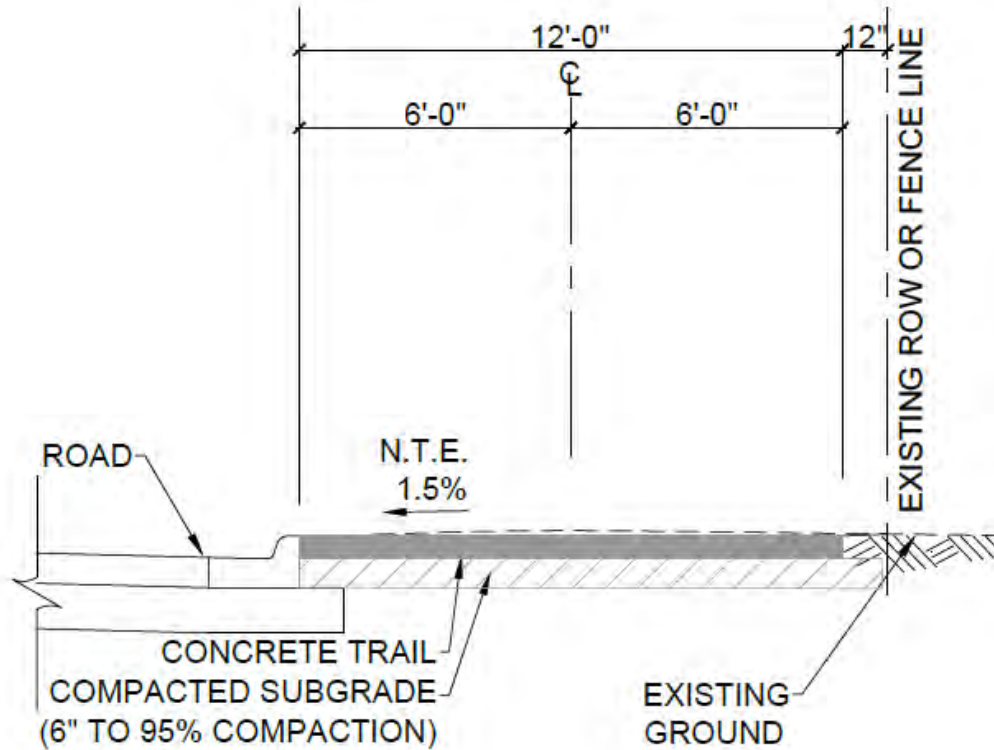

EXHIBIT L-2 – ADJACENT TO ROADWAY TYPICAL SECTION
N.T.S.

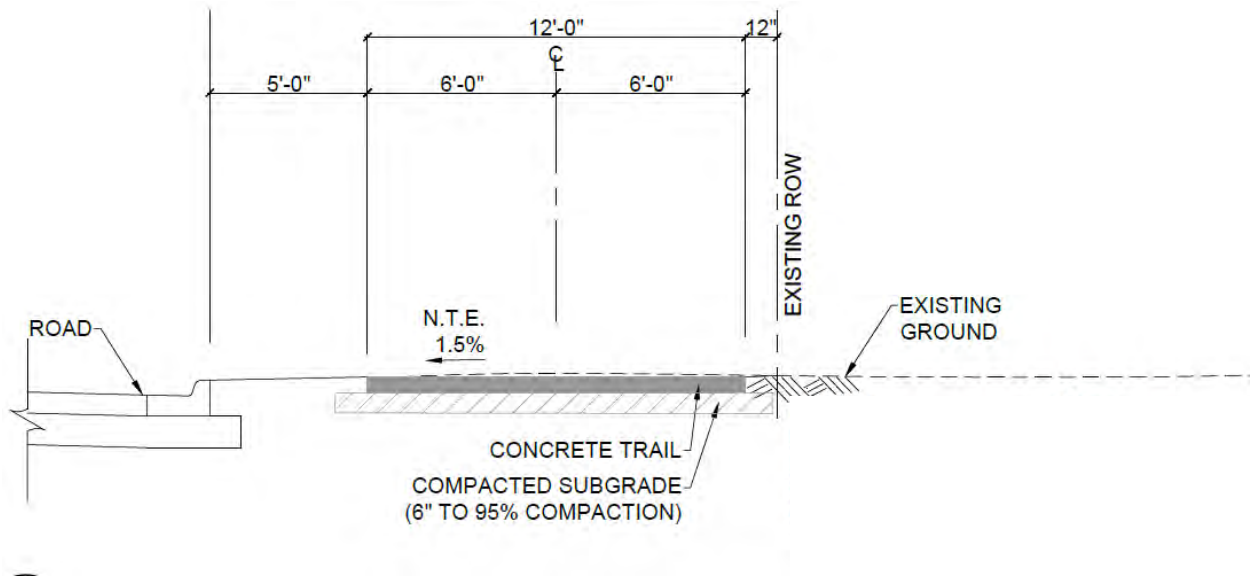

EXHIBIT L3 – ROADWAY TYPICAL SECTION
N.T.S.

I. IH-35E BICYCLE/PEDESTRIAN CROSSING – CONCEPT A



Lancaster Trail A- Alt: (IH 35E Undercrossing at Belt Line Road)***Trail Alignment***

Trail Alignment A will serve as an optional sidepath alignment which crosses under Belt Line Rd. and traverses on the south side of W. Belt Line Rd. in Lancaster. The sidepath will start underneath the IH 35E southbound frontage road in the DeSoto City limits utilizing a seawall on the creek side with a one-way valve (refer to Appendix B for concepts and discussions with TxDOT). The crossing underneath IH 35E and Belt Line Rd. requires the process of cutting into the embankment and the construction of two retaining walls on both sides of the sidepath, to prevent the sidepath from flooding (refer to Exhibit L-1). Once on the southeast side of Belt Line Rd. and IH 35E frontage road the sidepath will traverse up to the same elevation as Belt Line Rd. Once at grade, the sidepath will then cross Belt Line Rd. and end on the north side of the intersection.

Project Stakeholders

- City of Lancaster
- City of DeSoto
- TxDOT

Alignment and Engineering Constraints

- Final approvals and easements from TxDOT and Private Property Owners
- Coordination between City of DeSoto on construction timeline of IH 35E crossing

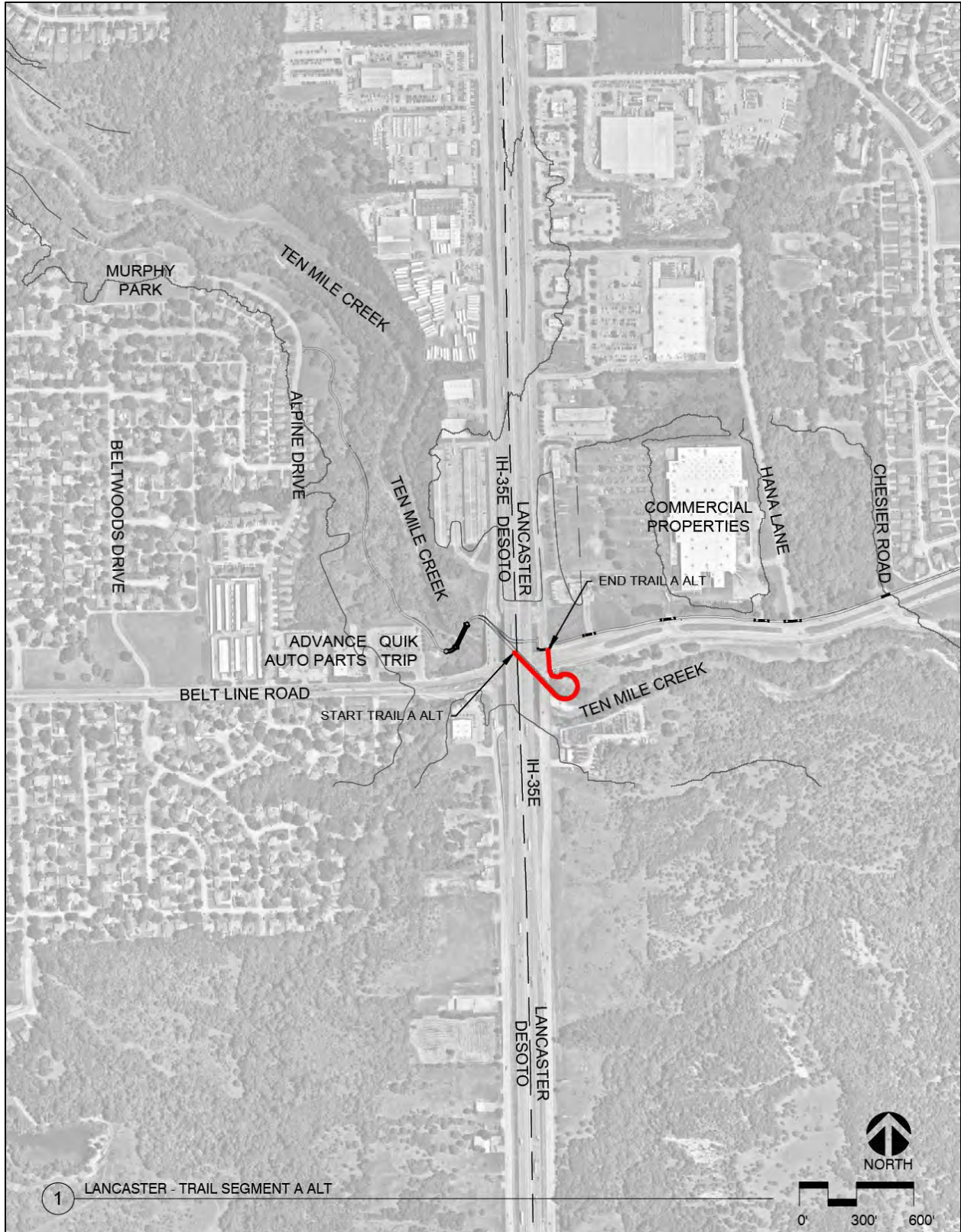

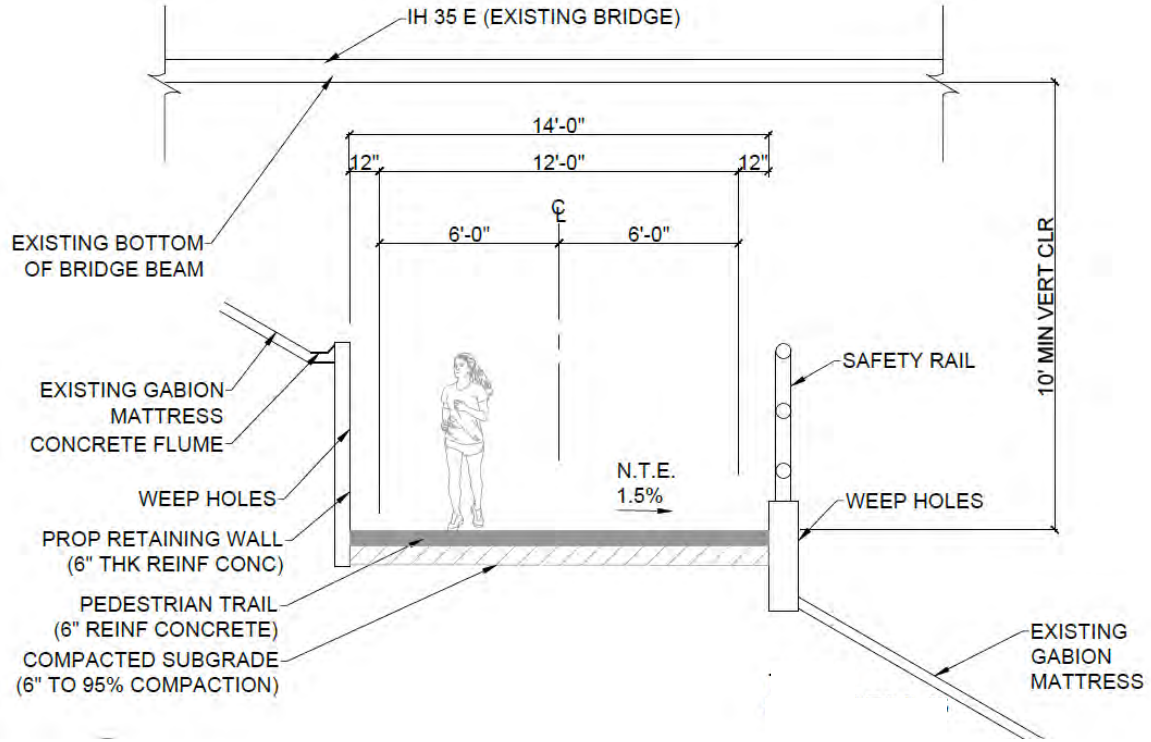

EXHIBIT L-1 – IH 35E UNDERPASS TYPICAL SECTION
N.T.S.

I. IH-35E BICYCLE/PEDESTRIAN CROSSING – CONCEPT C



Lancaster Trail B - W. Belt Line Road: (Pleasant Run Hike and Bike Trail to Dallas Avenue / SH 342)**Trail Alignment**

Trail Segment B will serve as a sidepath along W. Belt Line Rd. from Pleasant Run Rd. Hike and Bike Sidepath to W. Main St., then along the north side of Main St. from Pleasant Run Rd. to Dallas Avenue (SH 342).

The sidepath would replace the existing sidewalk along the north side of W. Belt Line Rd. from the existing Pleasant Run Hike and Bike Sidepath (approximately 200 feet west of Cloverleaf Dr.) to the intersection of W. Main St. (refer to Exhibit L-2). The sidepath alignment should not affect the existing overhead utility poles in the corridor.

The existing drainage swale along Main St. can be modified where necessary to accommodate the sidepath within the wide parkway. Detailed field survey would be required to verify the feasibility of regrading the ditches (refer to Exhibit L-4). The safety of sidepath and road users must be considered when designing modifications to the ditch system due to the possibility of steep side slopes of that may occur when accommodating the sidepath

An existing dual barrel drainage structure is present near east of the intersection of Belt Line Rd. and Quail Hollow Drive. This structure appears to be in good shape but may need slight modification to accommodate the sidepath. Detailed survey would be needed to assess the feasibility of reuse of the structure. There is also an existing bridge in between Quail Hollow Drive and Annette St. along Belt Line Rd. with ample, unused pavement width to accommodate the full sidepath width.

Along Main St. east of W. Belt Line Rd. near West Main Elementary School there is limited space within the street right-of-way. A curb adjustment to the outside vehicle lane would be necessary to replace the existing sidewalk with a 12-foot wide sidepath. Two additional areas require curbs to be adjusted along Main St. between Belt Line Rd. and Lancaster Town Square at Dallas Ave (SH 342).

Project Stakeholders

- City of Lancaster
- Franchise Utility Owners

Alignment and Engineering Constraints

- Final approvals and easements from Private Property Owners
- Further approval from city on curb adjustments along W. Main St.
- Terrain/Minimizing the retaining wall needs
- Existing drainage ditch on north side of W. Belt Line Rd.

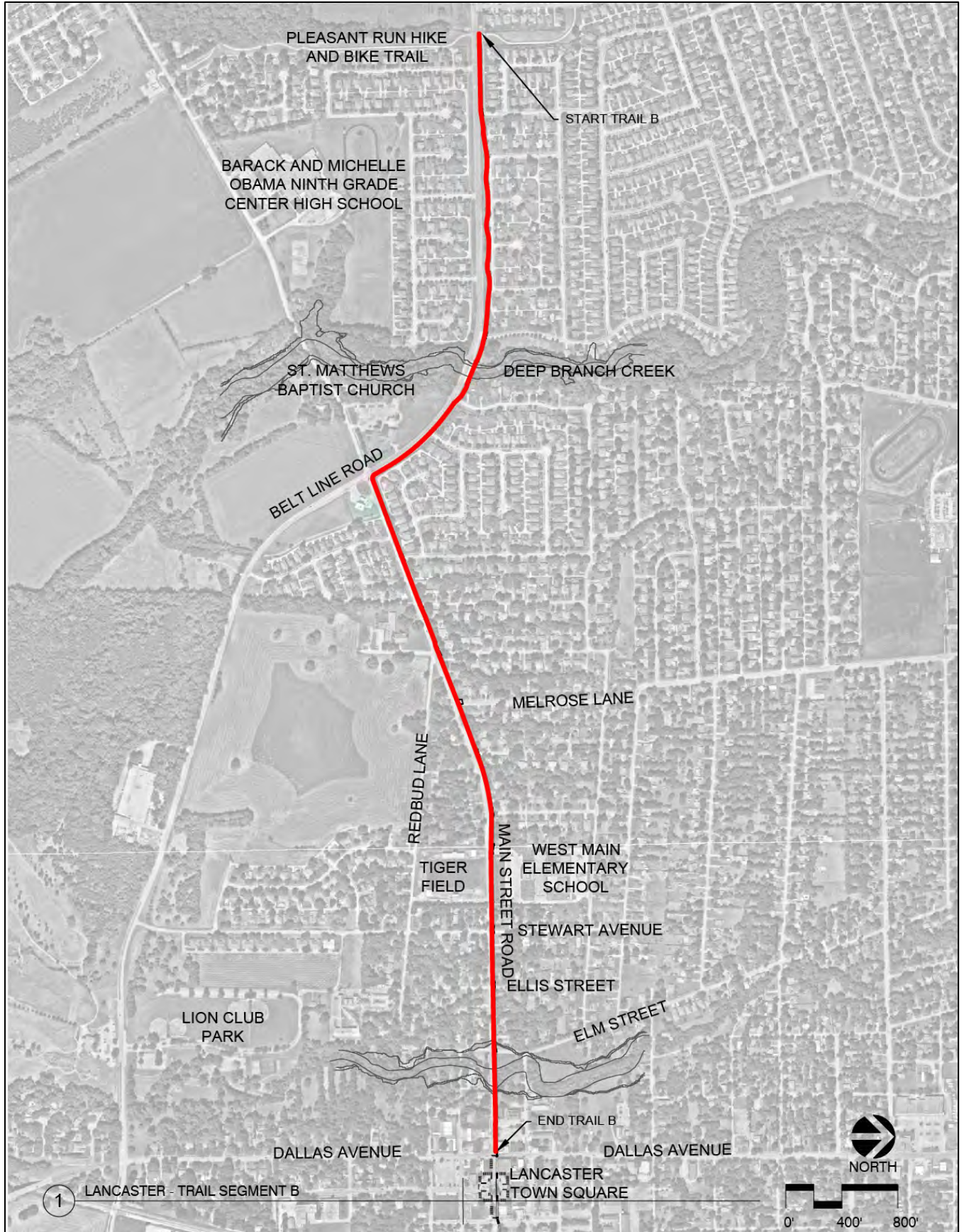

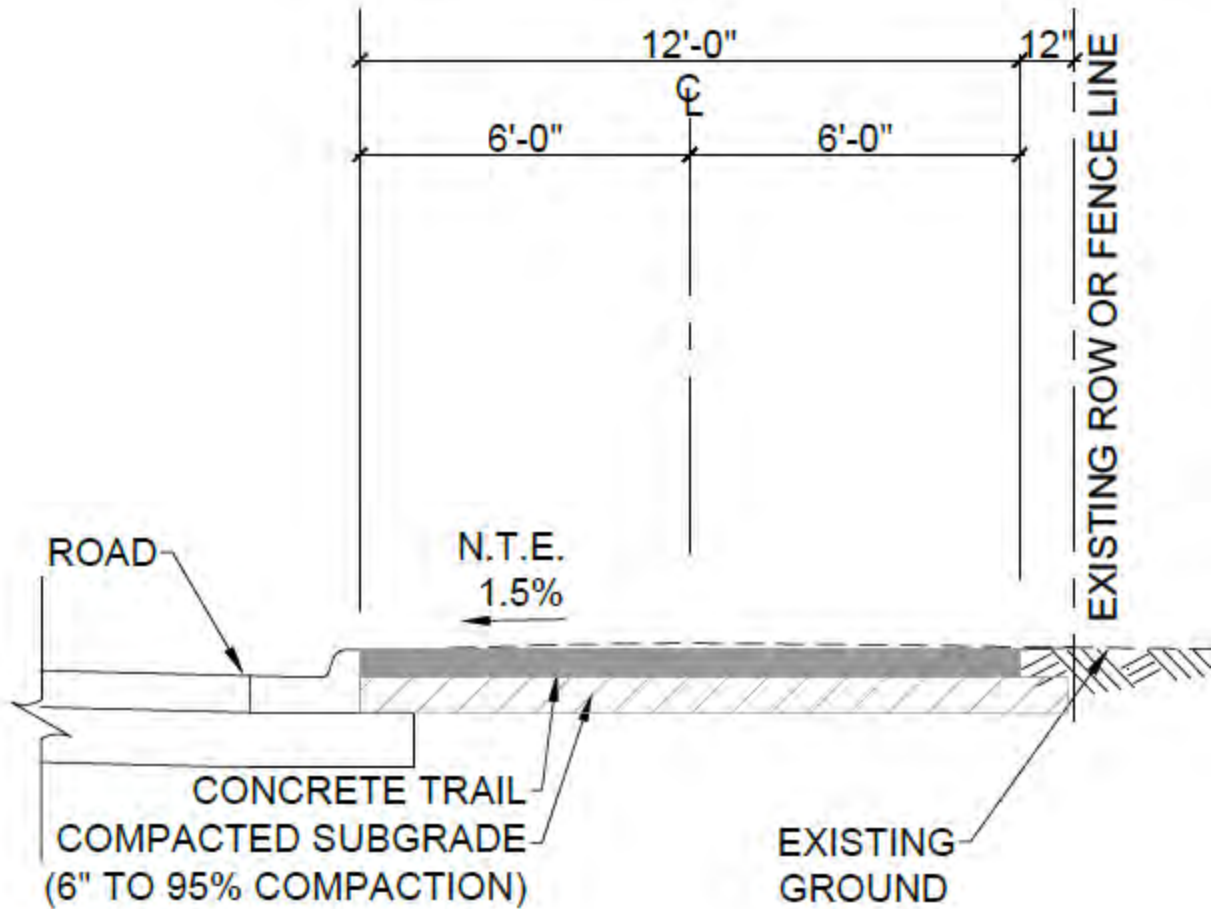

EXHIBIT L-2 – ADJACENT TO ROADWAY TYPICAL SECTION
N.T.S.

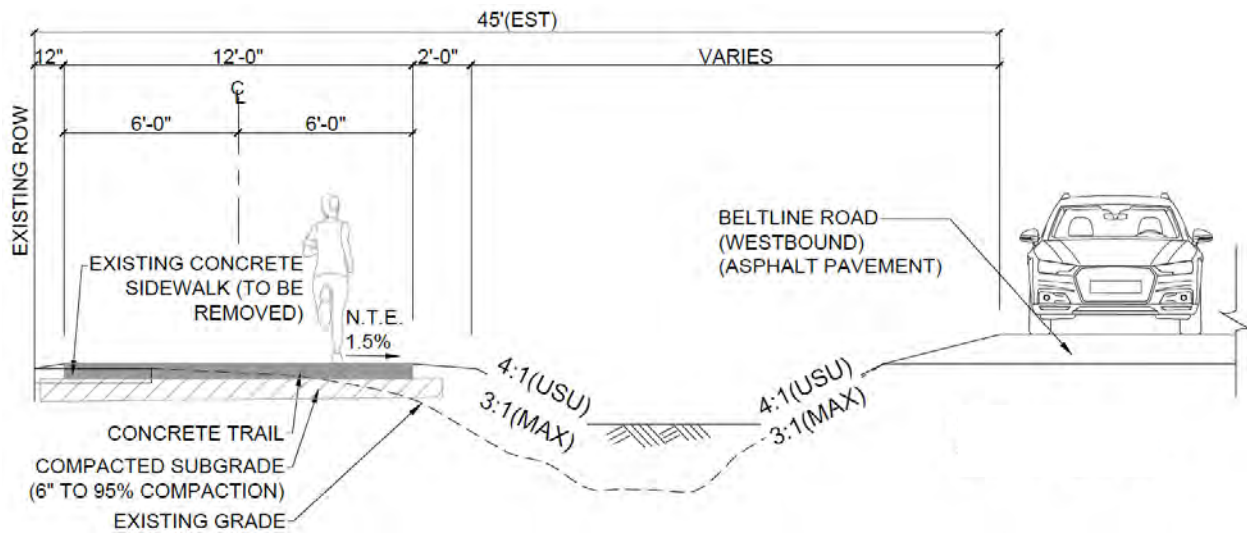

EXHIBIT L-4 – BELTLINE ROAD TYPICAL SECTION
N.T.S.

**Lancaster Trail C: E. Main Street (Dallas Avenue (SH342) - Lancaster Hutchins Road)
N. Lancaster Hutchins Road (Main St. - E. Pleasant Run Road)**

Trail Alignment

Trail Segment C will serve as a sidepath along E. Main St. through Lancaster Town Square east to Lancaster Hutchins Rd., then along the west side of N. Lancaster Hutchins Rd. from E. Main St. to E. Pleasant Run Rd. Various concepts to reconfigure Lancaster Town Square were identified during the study process. City staff selected Concept A (shown below) as the preferred option. The concept would reconfigure parking layout and provide an enlarged central gathering area to create a more pedestrian focused space. The existing Lancaster Downtown Square layout has 75 parking spaces, and with the proposed design adding two additional parking spaces, this will make 77 total parking spaces. All the reconfiguration concepts discussions with city staff are provided in Appendix B. Appendix C contains Lancaster Town Square existing configuration and proposed concepts.

DOWNTOWN LANCASTER – CONCEPT A (Preferred Option)

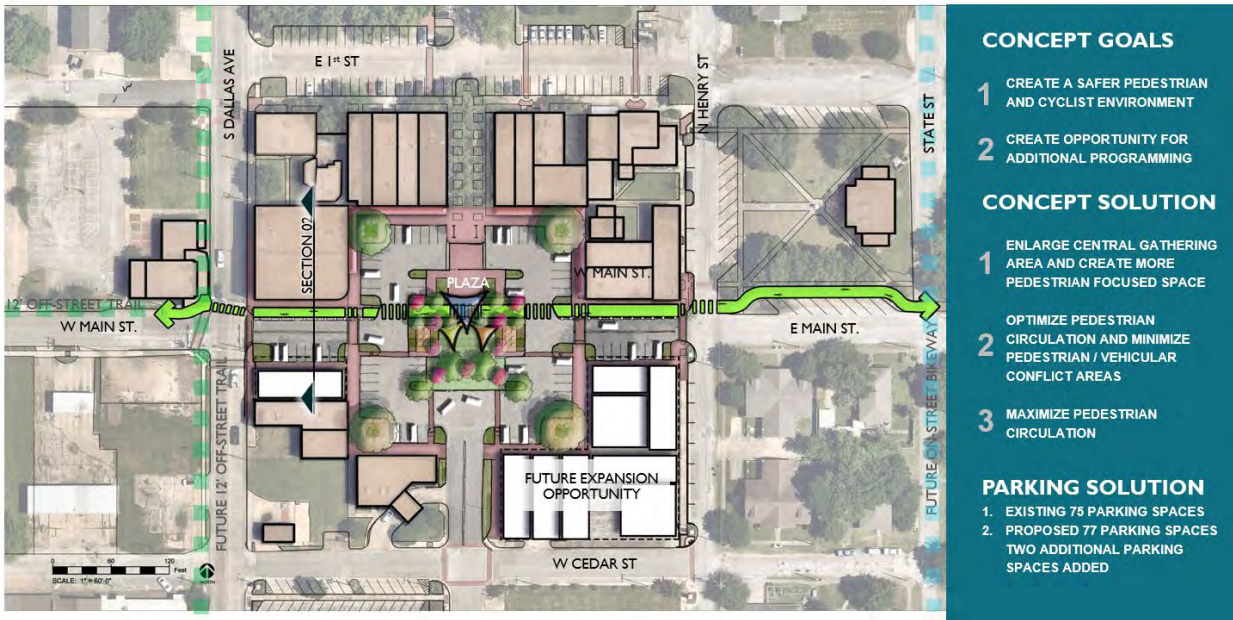

East of Henry St., on the eastern side of Lancaster Town Square, the sidepath will continue along the north side of Main St. An at-grade crossing of the BNSF railroad would be installed with the sidepath continuing east to connect with Rocky Crest Park.

A series of drainage swales are located adjacent to the E. Main St. right-of-way lines. The drainage swales will shift from the right-of-way line inward between the proposed sidepath and the roadway (refer to Exhibit L-5).

The sidepath is proposed to be located one foot inside the right-of-way and is generally sloped towards N. Lancaster-Hutchins Rd. The sidepath alignment should not affect the existing overhead utility poles in the corridor. Private driveway approaches may need to be rebuilt based on drainage and sidepath implications.

The existing ditch along Lancaster Hutchins Rd. appears to have enough room to be relocated when the sidepath is installed and detailed field survey would be required to verify the feasibility of shifting the drainage swale. Due to potential drainage from steep side slopes, the safety of sidepath and road users must be considered when designing the ditch and sidepath. In tight areas, the open ditch drainage system along Lancaster Hutchins Rd. may have to be converted to an enclosed pipe. This alternative would have fewer safety issues for sidepath and road users but would increase the construction costs. For this reason, the construction of extensive enclosed drainage system should be deferred until the roadway would need to be widened.

Project Stakeholders

- City of Lancaster
- St. Paul Free Will Baptist Church
- New Friendship Church
- Private Residential and Commercial Property Owners
 - Some tree removal north of E. 3rd St. needed
 - Some clearing and grubbing required for a couple blocks south of Pleasant Run Rd.
- Franchise Utility Owners
- BNSF Railway

Alignment and Engineering Constraints

- Final approvals and easements from Private Property Owners
- Navigating existing drainage courses and floodplain requirements
- Managing the sidepath cross slopes along the BNSF Railway
- Further design of Lancaster Town Square
- Terrain/Minimizing the retaining wall needs
- Existing drainage ditch on west side of roadway
- Large drainage outfall at 531 S. Lancaster Hutchins Rd.



APPENDIX A**AGENCY CONTACTS****NCTCOG**

Kevin Kokes, AICP
 Program Manager – Sustainable
 Development Program
 Phone: 817.695.9275
 Email: kkokes@nctcog.org

Patricia Rohmer, PE
 Project Engineer – Streamlined Project
 Delivery/Data Management
 Phone: 817.608.2307
 Email: prohmer@nctcog.org

Matt Fall
 Senior Planner
 Phone: 817.695.9207
 Email: mfall@nctcog.org

City of Cedar Hill

Shawn Ray
 Parks Superintendent
 Phone: 972.291.5100 (ext.2844)
 Email: shawn.ray@cedarhilltx.com

Robert Woodbury
 City Engineer
 Phone: 972.291.5126 (ext. 2812)
 Email: Robert.woodbury@cedarhilltx.com

City of DeSoto

Tony Irvin, PE
 Assistant Director - City Engineer
 Phone: 972.230.7309
 Email: tirvin@desototexas.gov

City of Duncanville

Bart Stevenson
 Director of Parks and Recreation
 Phone: 972.780.5076
 Email: bstevenson@duncanville.com

Timothy Hamilton
 Parks Superintendent
 Phone: 972.780.5072
 Email: thamilton@duncanville.com

City of Lancaster

Vicki Coleman
 Development Services Director
 Phone: 972.218.1217
 Email: vcoleman@lancaster-tx.com

Lisa Wube
 Director of Parks and Recreation
 Phone: 972.218.3710
 Email: lwube@lancaster-tx.com

Mike Rasco
 Assistant Director Parks and Recreation
 Phone: 972.218.3709
 Email: mrasco@lancaster-tx.com

Andrew Waits
 Public Works Director
 Phone: 972.218.2326
 Email: await@lancaster-tx.com

Bester Munyaradzi, AICP
 Senior Planner
 Phone: 972.218.1317
 Email: bmunyaradzi@lancaster-tx.com

Dallas County

Micah Baker
 Senior Transportation Planner
 Phone: 214.653.7465
 Email: Micah.baker@dallascounty.org

Minesha Reese
 Transportation Planner
 Phone: 214.653.7151
 Email: minesha.reese@dallascounty.org

TxDOT

Maher Ghanayem
 Phone: 214.320.6691
 Email: maher.ghanayem@txdot.gov

Amanda Moser, PE
 Transportation Engineer
 Email: Amanda.Moser@txdot.gov

Nathan Petter, PE
 Email: Nathan.Petter@txdot.gov

Travis Campbell, PE
 Email: Travis.Campbell@txdot.gov

James Palmgren, PE
 Email: James.Palmgren@txdot.gov

City of Dallas

Gus Khankarli, PE
Engineering Department
Email: ghassan.khankarli@dallascityhall.com

Jessica Scott, AICP
Transportation Department
Email: jessica.scott@dallascityhall.com

Kathryn Rush, AICP
Transportation Department
Email: Kathryn.rush@dallascityhall.com

APPENDIX B

Southern Dallas Co. Veloweb – TxDOT Design Review Meeting

Meeting Date: March 2, 2021
Location: Microsoft TEAMS

Attendees:

NCTCOG – Kevin Kokes, Matt Fall, Pat Rohmer, Robert Kozub
 Halff Associates – David Buchanan, Andrew Ehlers
 TxDOT – Maher Ghanayem, Liang Ding, Zaheerul Arefeen
 City of Cedar Hill – Robert Woodbury
 City of DeSoto – Tony Irvin, Nathan Busby
 City of Duncanville – Bart Stevenson, Timothy Hamilton
 City of Lancaster – Michael Rasco
 Dallas County – Micah Baker, Minesha Reese

Overview

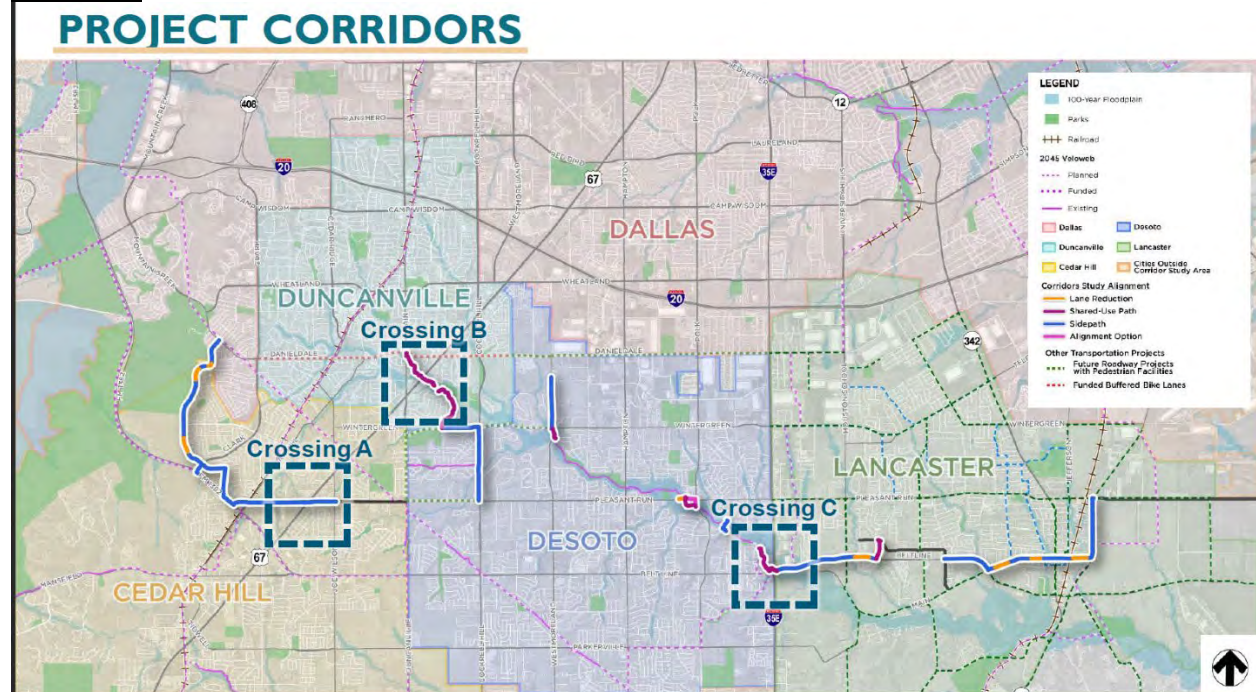

1. Alignment study to identify the preferred alignment across the southern Dallas County. Highway crossings include US 67 at Pleasant Run Rd. (Cedar Hill), US 67 at Ten Mile Creek (Duncanville) and IH 35E at Belt Line Rd. in DeSoto and Lancaster.
2. Final deliverables are a five percent design schematic, Opinion of Probable Construction Cost (OPCC) and environmental report.

Crossing A: Cedar Hill (US 67 at Pleasant Run Rd.)
CEDAR HILL - ALIGNMENT

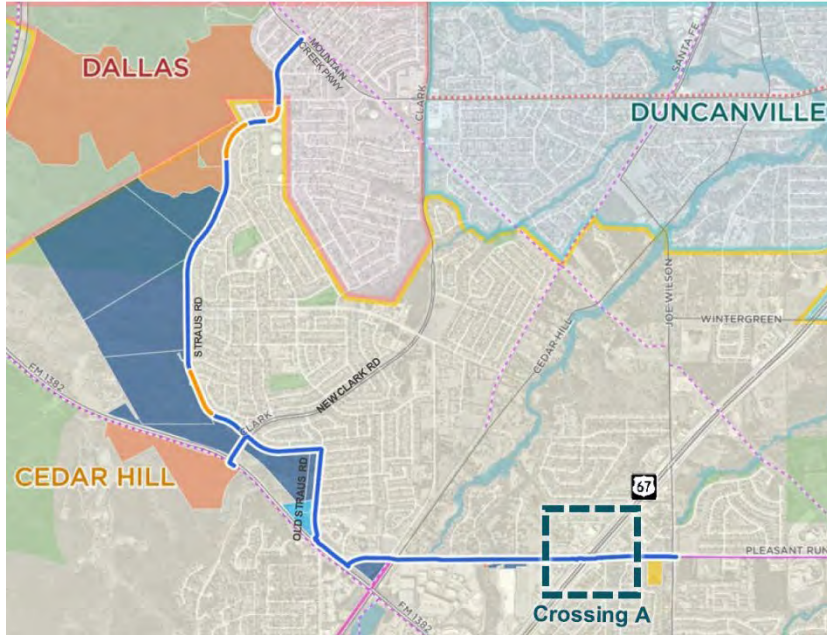

Cedar Hill Alignment

1. Crossing A: US 67 Crossing on Pleasant Run Road

- **Constraint**
 - Provide a safe pedestrian and bicycle crossing with minimal pedestrian vehicular conflict
 - Utilize existing open space for approach
- **Solution**
 - Utilizes a separated pedestrian bridge with intermittent piers to shorten bridge lengths and reduce cost
 - Utilizes the existing space along the open areas of US 67 frontage road to create accessible trail connections to the bridge crossing

6

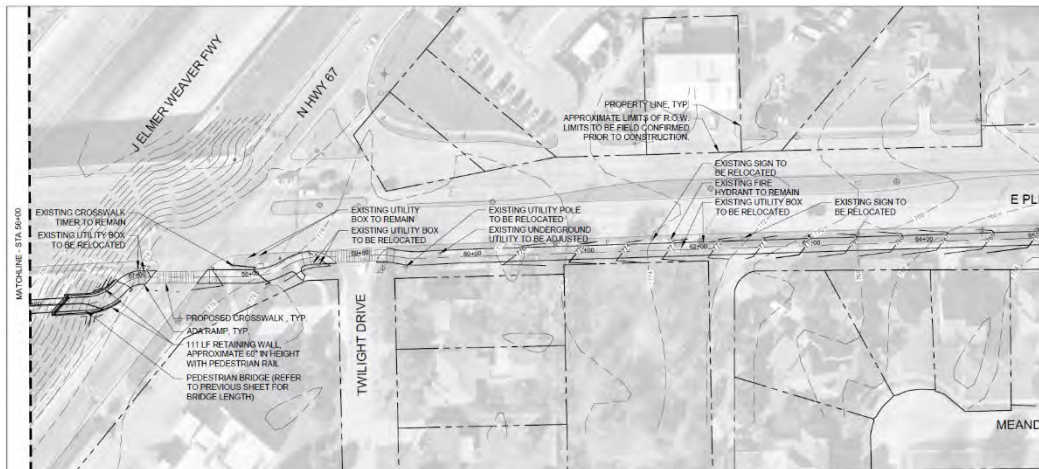
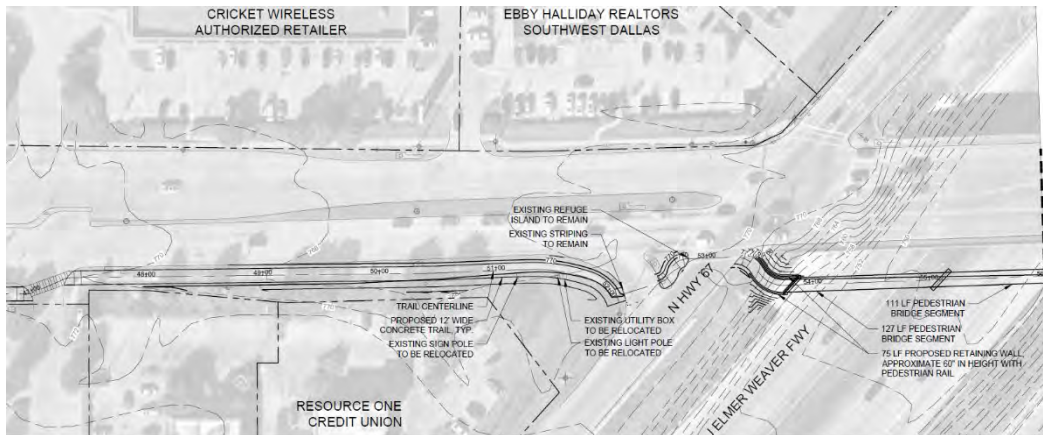

1. Stand- alone pedestrian bridge proposed on the south side of Pleasant Run Rd.
2. In response to Robert Woodbury's question regarding the potential implementation of Texas U-Turns, TxDOT confirmed none are planned. Half Associates affirmed concepts were considered and the proposed location of the pedestrian bridge would not interfere with future Texas U-Turn implantation. The graphic below was presented at the September 11, 2020 meeting with TxDOT.

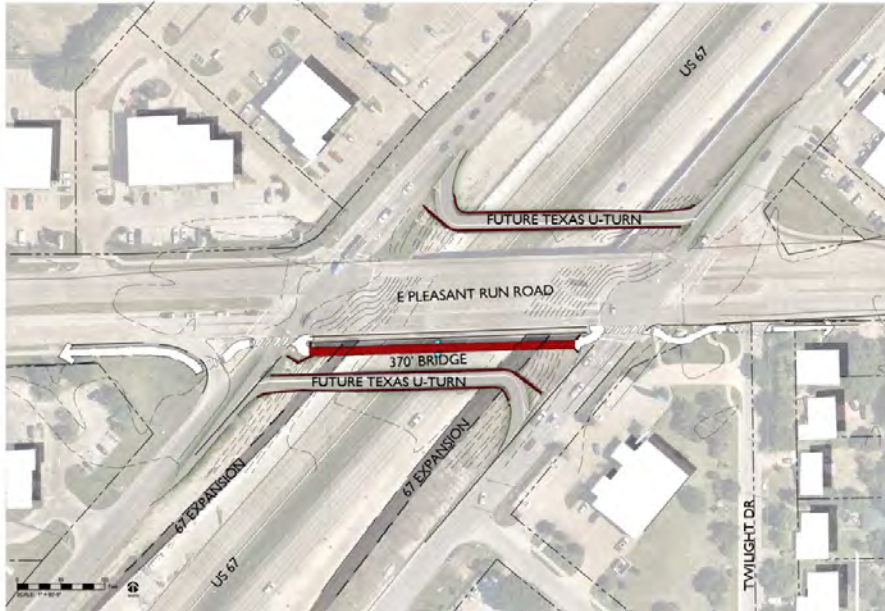

Crossing B: Duncanville US 67 at Ten Mile Creek
DUNCANVILLE - ALIGNMENT

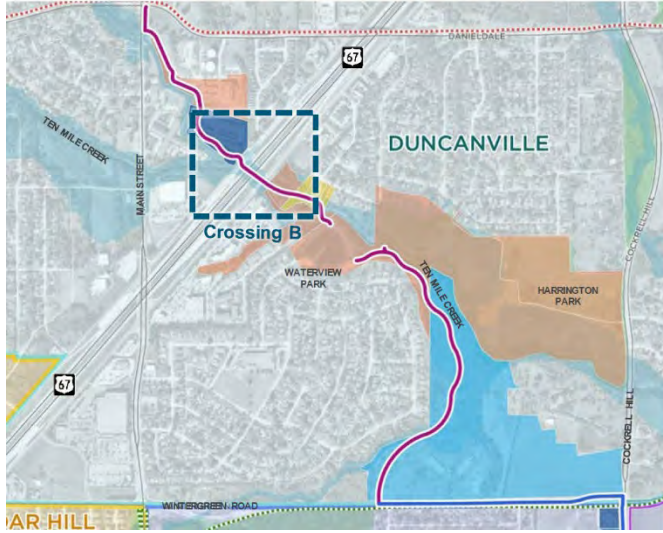

Duncanville Alignment

1. Crossing B: US 67 Undercrossing at Ten-Mile Creek

- **Constraints**
 - Elevate the trail to maintain proper vertical clearances and minimize prolonged flooding and reduce maintenance issues
- **Solution**
 - Utilize a combination of low and high walls to maintain proper ADA cross slopes under US 67 service road

7

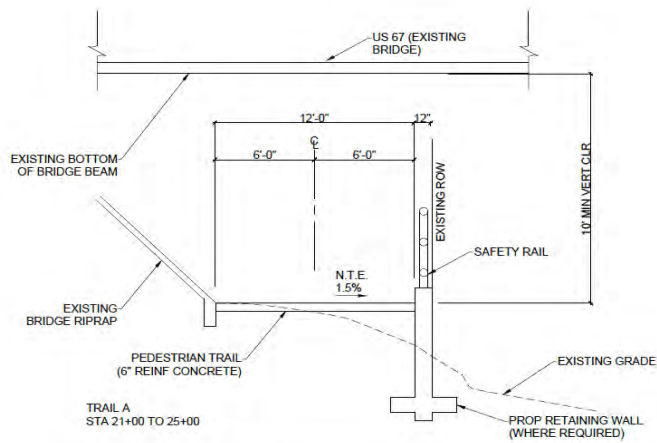
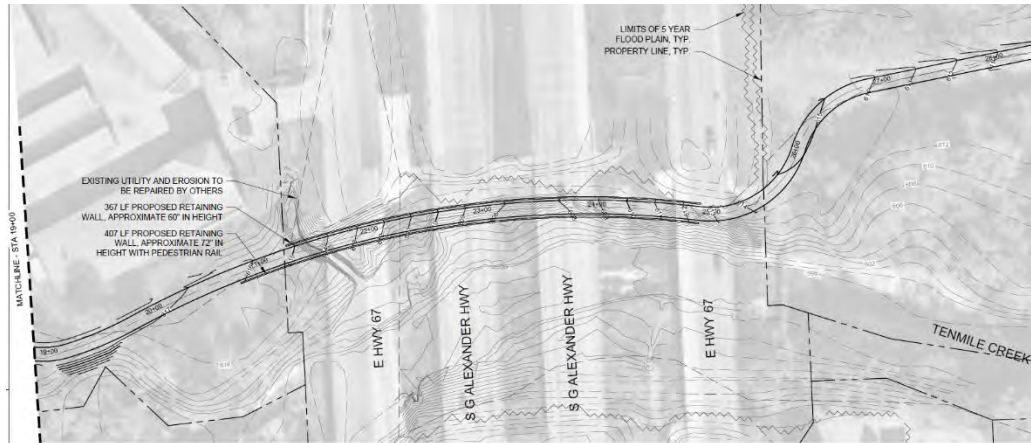

4 UNDER US 67 CROSSING TYPICAL SECTION
 1/4" = 1'-0"

1. Proposed crossing under US 67 to Waterview Park.
2. NCTCOG pointed out the existing erosion concern under the US 67 bridge. TxDOT staff verified the issue was to be addressed by the TxDOT Area Office Maintenance Department (Nathan Petter and Amanda Moser). Halff Associates will provide photos to Duncanville, NCTCOG and TxDOT for reference and evaluation. Maher G. also noted this location to be on-system and under the TxDOT jurisdiction. However, rehabilitation costs could be allocated to city or county if the trail construction is not administered/let by TxDOT. Trail construction would begin depending on funding, FY 2023 at the earliest.
3. Typical Section
 - Halff Associates presented the proposed typical section, noting the trail to be designed as highly elevated as possible to minimize impacts and use of the existing ledge for this purpose.
 - TxDOT staff noted typically two-foot offsets are needed on both sides of the path and confirmed one-foot offsets were acceptable.
 - Halff Associates verified a 42-inch height was proposed for the safety rail and not chain-link fence.
 - TxDOT staff requested typical section be revised to include drainage details illustrating water flow under the trail, through the existing bridge riprap, under the pedestrian trail and through the proposed retaining wall.

Crossing C: DeSoto/Lancaster (IH 35E at Belt Line Rd.)
DESOTO - ALIGNMENT

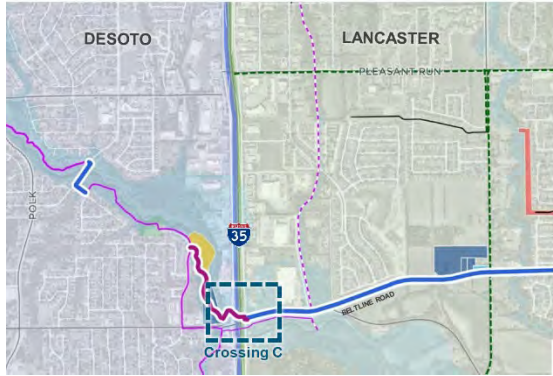

DeSoto Alignment

2. Crossing C: IH 35-E Undercrossing at Belt Line Road

- Constraints**
 - Provide a safe bicycle and pedestrian east-west crossing under IH-35E
 - Find an appropriate location for the proposed bicycle and pedestrian bridge
 - Design trail to maintain proper vertical clearances and minimize prolonged flooding and reduce maintenance costs
- Solution**
 - Creek crossing between overhead electrical line and IH-35E southbound frontage road
 - Utilize a 75' boardwalk to navigate the creek side slopes and reduce impact to valley storage
 - Utilize a low and high wall to maintain proper ADA cross slopes under IH-35 E service road

DESOTO- IH-35 UNDERCROSSING

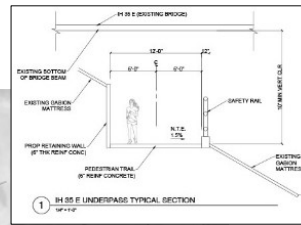
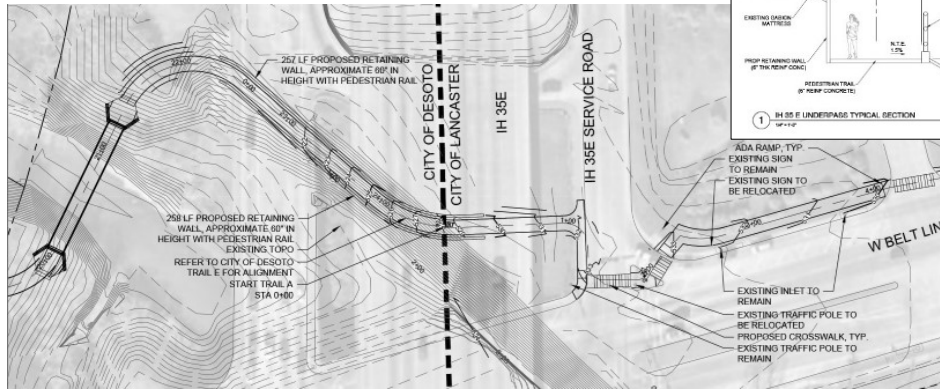

DESOTO- IH-35 UNDERCROSSING

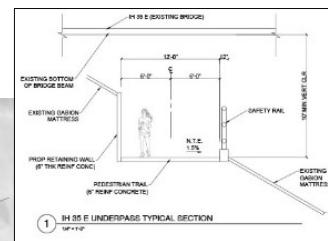
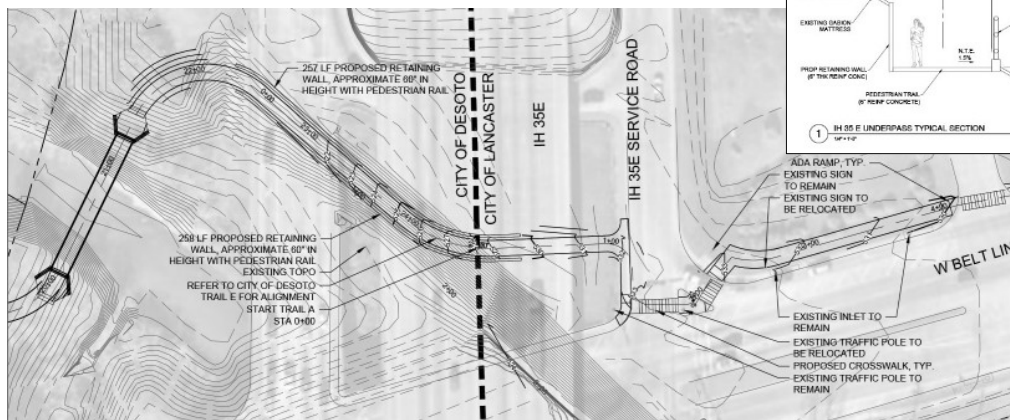

1. Typical Section – Half Assoc. to include drainage flow details.

2. Lighting

- TxDOT suggests can add lighting to top of safety rail. Halff Assoc. recommended lighting embedded within wall or independent solar lighting or hanging lighting fixtures. Evaluation of lighting fixtures will be provided to determine the best options for inundation.
- Lighting already included in OPCCs for under crossings (including inflation). David Buchanan will add to concepts and include lighting in OPCCs.

Next Steps / Action Items

1. TxDOT staff provide comments on five percent schematic, cost estimate and environmental report to NCTCOG by March 15th.
2. NCTCOG – Follow up meeting tentatively, March 29th, if needed. Final review meeting if needed – present final deliverables
3. Halff Associates
 - Revise typical sections to add offsets from retaining wall and railing. OPCCs should include for the worst-case scenario for the reinforced concrete retaining walls.
 - Revise typical sections to include drainage detail with water flow under the trail.
 - Add lighting to detail and OPCCs.
 - Provide photos of erosion under US 67 in Duncanville to City staff, NCTCOG and TxDOT Area Office.

APPENDIX C

DOWNTOWN LANCASTER – EX. CONDITIONS

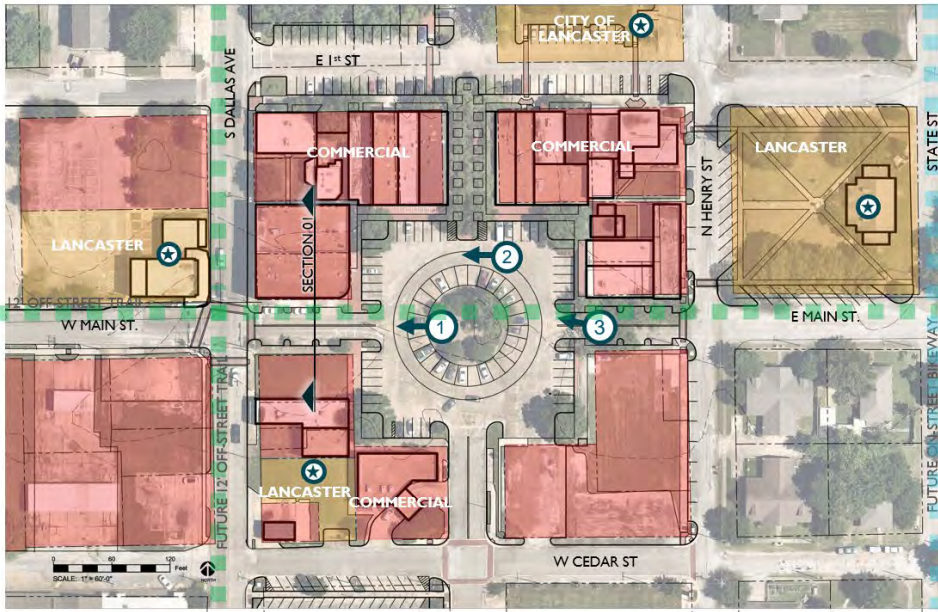

DOWNTOWN LANCASTER – CONCEPT A (Preferred Option)

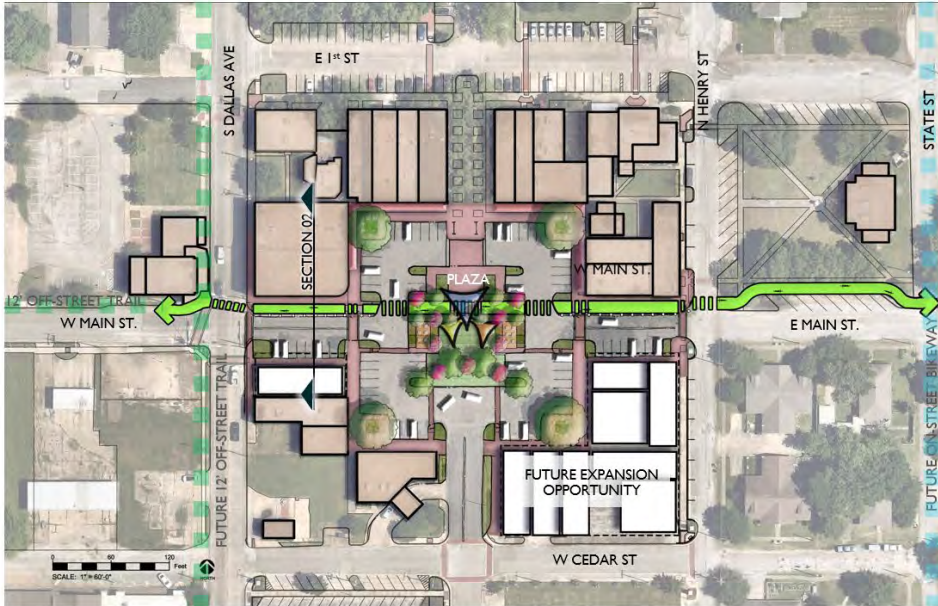

CONCEPT GOALS

- 1 CREATE A SAFER PEDESTRIAN AND CYCLIST ENVIRONMENT
- 2 CREATE OPPORTUNITY FOR ADDITIONAL PROGRAMMING

CONCEPT SOLUTION

- 1 ENLARGE CENTRAL GATHERING AREA AND CREATE MORE PEDESTRIAN FOCUSED SPACE
- 2 OPTIMIZE PEDESTRIAN CIRCULATION AND MINIMIZE PEDESTRIAN / VEHICULAR CONFLICT AREAS
- 3 MAXIMIZE PEDESTRIAN CIRCULATION

PARKING SOLUTION

1. EXISTING 75 PARKING SPACES
2. PROPOSED 77 PARKING SPACES
- TWO ADDITIONAL PARKING SPACES ADDED

DOWNTOWN LANCASTER – CONCEPT B

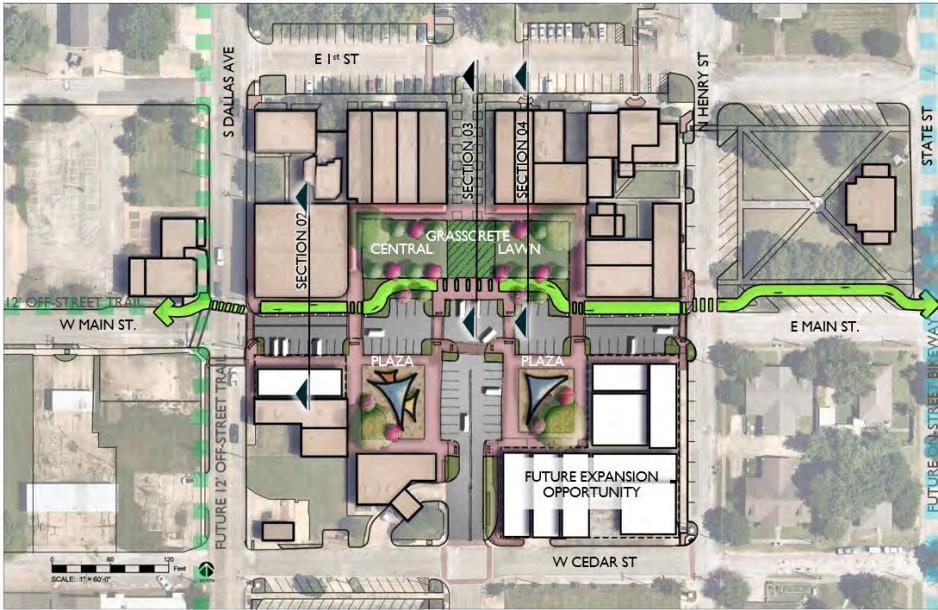

CONCEPT GOALS

- 1 CREATE A SAFER PEDESTRIAN AND CYCLIST ENVIRONMENT
- 2 CREATE OPPORTUNITY FOR ADDITIONAL PROGRAMMING

CONCEPT SOLUTION

- 1 CREATION OF A CENTRAL LAWN AREA TO FOCUS THE SPACE MORE ON THE PEDESTRIAN
- 2 UTILIZE GRASSCRETE TO ALLOW FOR FARMERS MARKET OR FOOD TRUCKS TO DRIVE ON THE CENTRAL LAWN AREA
- 3 OPTIMIZE PEDESTRIAN CIRCULATION AND MINIMIZE PEDESTRIAN / VEHICULAR CONFLICT AREAS.

PARKING SOLUTION

1. EXISTING 75 PARKING SPACES
2. PROPOSED 60 PARKING SPACES

DOWNTOWN LANCASTER – CONCEPT C

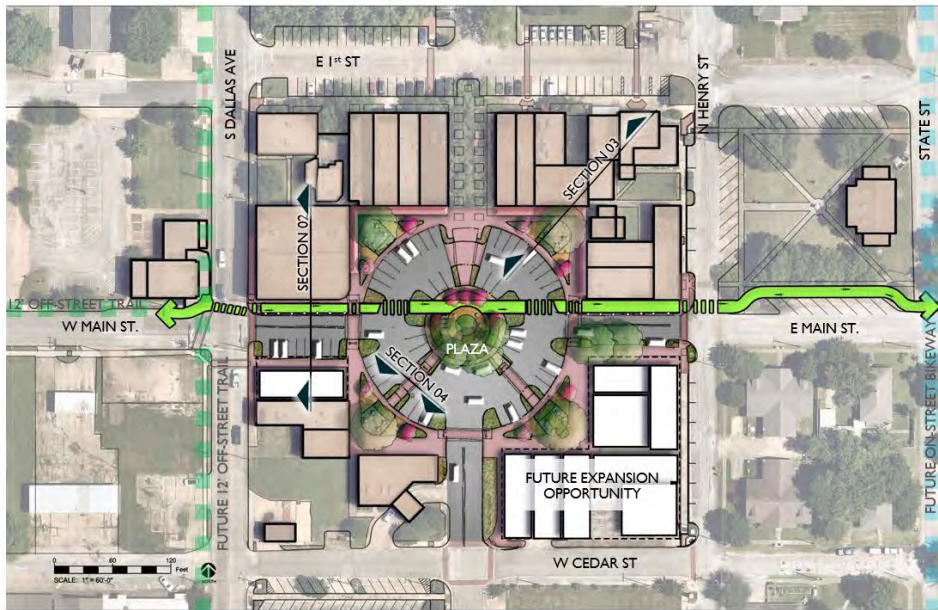

CONCEPT GOALS

- 1 CREATE A SAFER PEDESTRIAN AND CYCLIST ENVIRONMENT
- 2 CREATE OPPORTUNITY FOR ADDITIONAL PROGRAMMING

CONCEPT SOLUTION

- 1 PROVIDE A CENTRAL REFUGE FOR CYCLIST BY PROVIDING SHADE, SEATING, AND BIKE MAINTENANCE TOOLS.
- 2 ACTIVATE CORNERS FOR PEDESTRIAN REST AND SHADE
- 3 MAINTAIN EXISTING TRAFFIC PATTERN
- 4 SLOW DOWN TRAFFIC THROUGHOUT WITH RAISED PEDESTRIAN CROSSINGS.

PARKING SOLUTION

1. EXISTING 75 PARKING SPACES
2. PROPOSED 56 PARKING SPACES